



LINEA 8800-9000-9500

**LINEA J**

**VIOLETA**

**2025**

LINEA 38000



**33060**

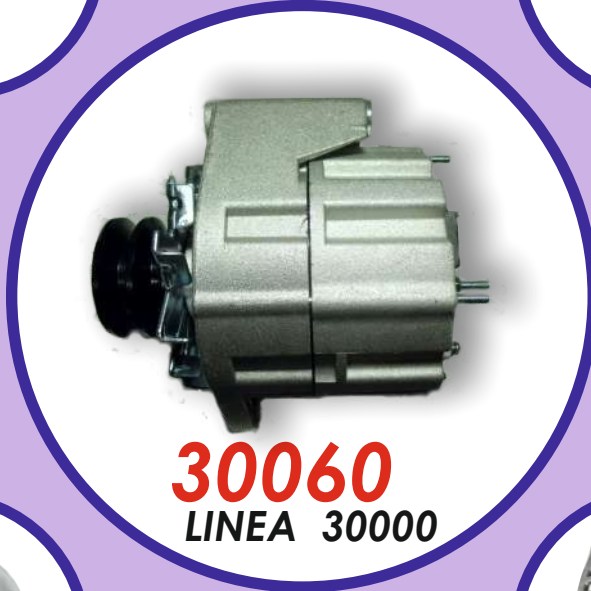

**30060**

LINEA 30000



**34060**

LINEA 33000

LINEA 34000



LINEA 35000



LINEA 36000



LINEA 15000

# ALTERNADORES

ALTERNADORES  
ROTORES  
ESTADORES  
POLEAS

**30007** 12V  
**30070** 24V

Tipo Lucas



Universal  
12V70A/C/R - - 24V50A/C/R



**30097** 200A  
**30107** 210A

Tipo Delco

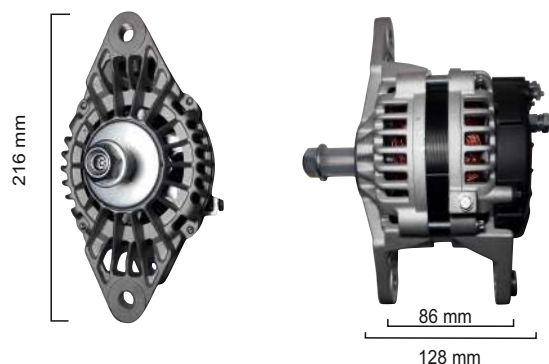

Universal Perkins, Ford, GM  
12V - c/r 28 SI Reforzado



**30008**

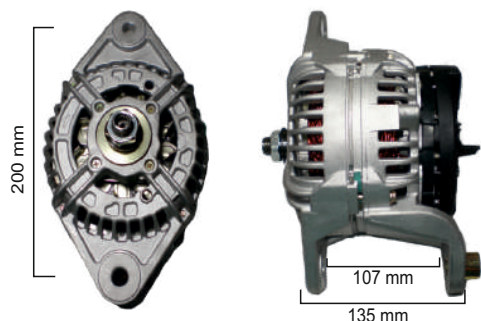

24V - 100A  
C/R Universal



**30059** 24V 100A C/R  
**30082** 24V 150A C/R

Tipo Bosch



Ruleman grande 62 mm  
Simil 30008



**30018** VMV **22SI** 24V  
**30005** VMV **22SI** 12V  
**30005A** VMV **21SI** 12V

Tipo Delco Remy

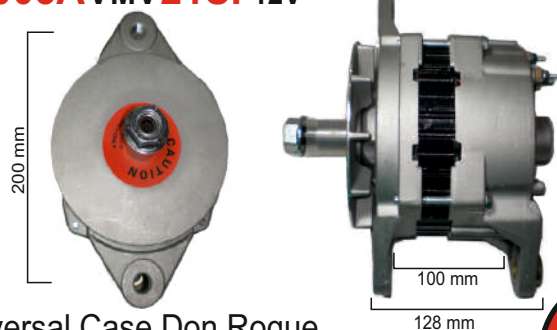

Universal Case Don Roque  
12V - 150A - C/R  
Opcional 24V

Rotor:33005  
Estator:34005



**30053**

Tipo Delco

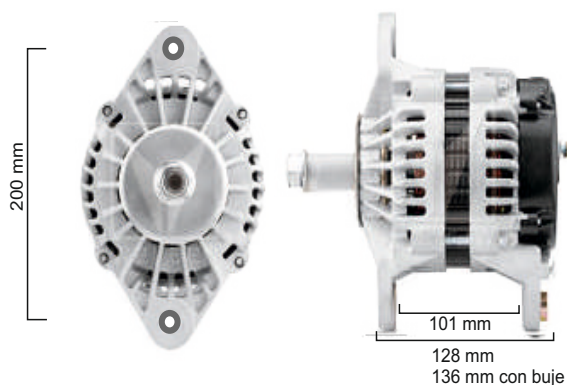

12V - 145A - C/R  
Universal tipo Avi



**30054**

Tipo Bosch

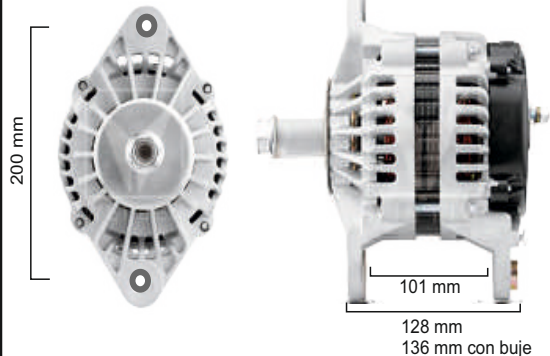

24V - 70A - C/R  
Universal



**30038**

Tipo Delco

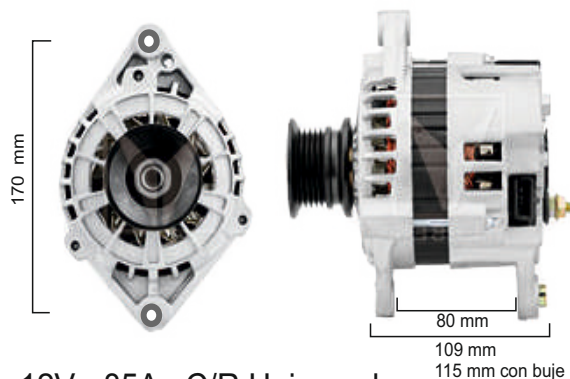

12V - 85A - C/R Universal



**30002** 12V - 140A - C/R

Tipo Bosch

**30084** 24V - 100A - C/R

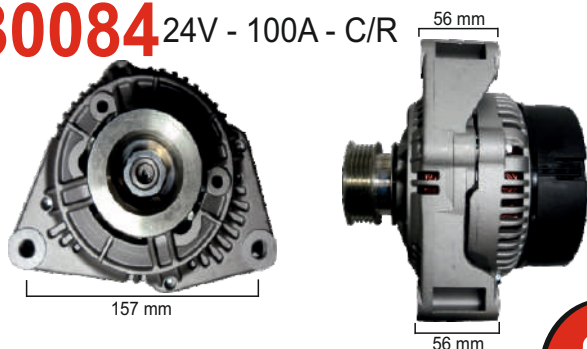

Universal línea agrícola



**30044** 12V - 150A - C/R

Tipo Delco

**30083** 12V - 200A - C/R

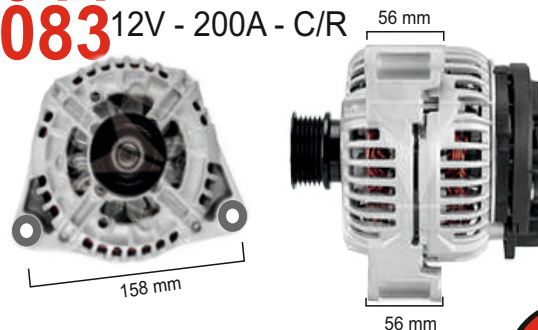

JHON DEERE 7730  
MOTOR POWER SWIFT  
UNIVERSAL AGRÍCOLA



**30010**

Tipo Bosch

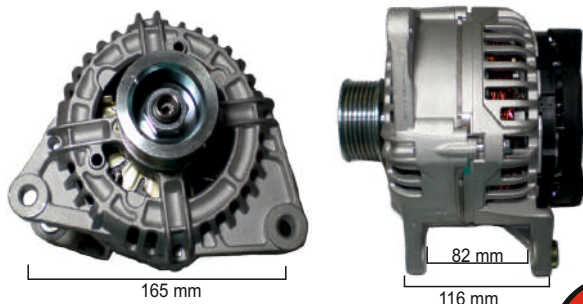

Fiat Tector Cavallino - 24A - 90A  
C/R Universal



**30012**

Tipo Bosch

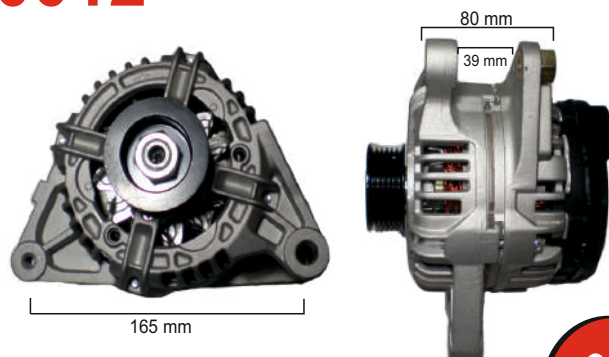

12V - 80A  
C/R Universal



**30035**

Tipo Hitachi

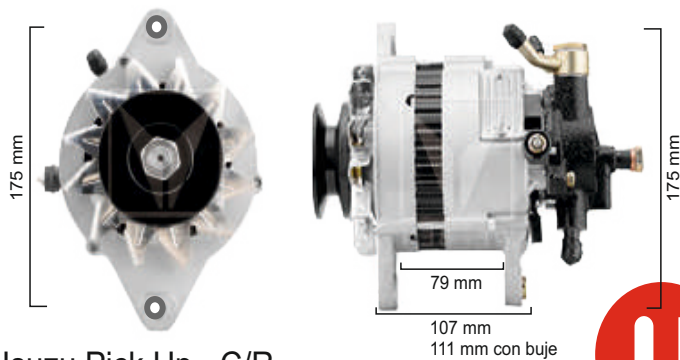

Isuzu Pick Up - C/R  
12 - 70A - Con depresor



**30037**

Tipo Hitachi

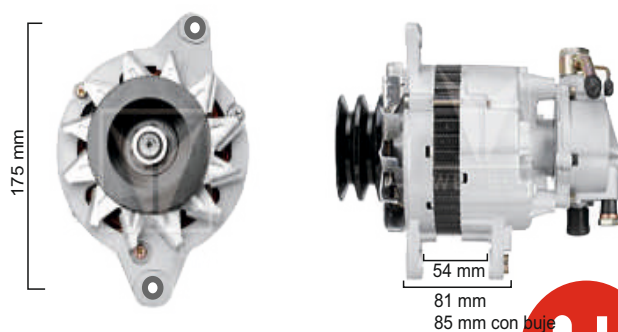

Isuzu Pick Up - C/R  
12V - 70A - Con depresor



**30036**

Tipo Hitachi

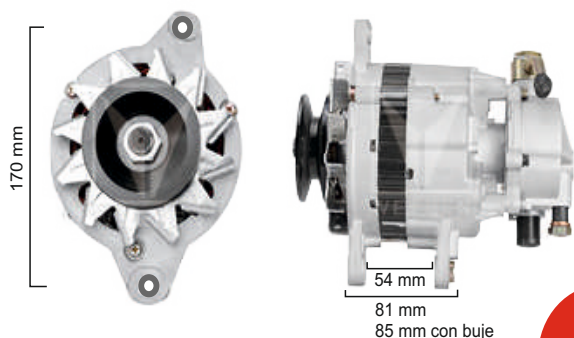

Isuzu Pick Up - C/R  
12V - 70A - Con depresor



**30071**

Tipo Bosch

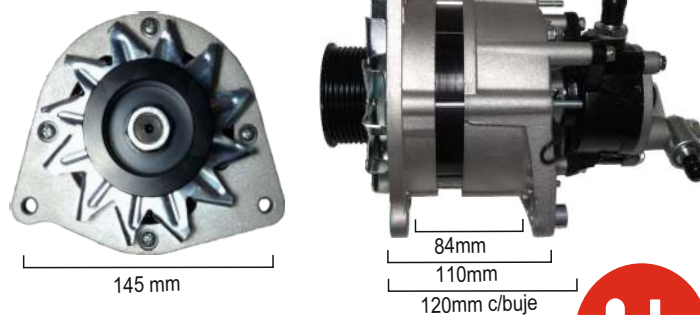

Ford Ranger Maxion  
12V 110A Con Depresor

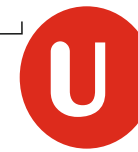

**30039**

Tipo Delco

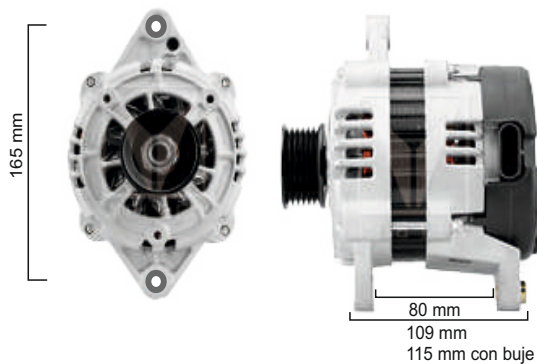

12V - 80A - C/R Universal



**30041**

Tipo Delco

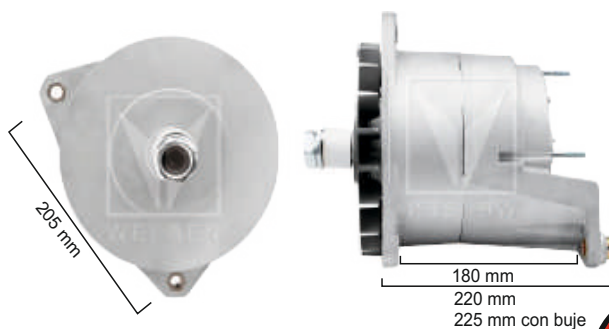

24V - 140A - C/R  
Scania - Línea Buses



**30052**

Tipo Delco

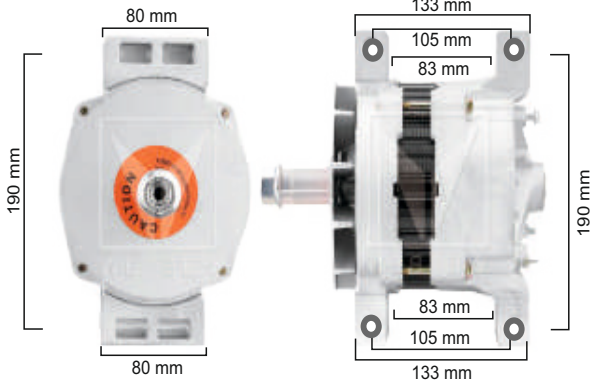

24V - 80A - C/R  
Universal pata cruzada



**30051**

Tipo Delco

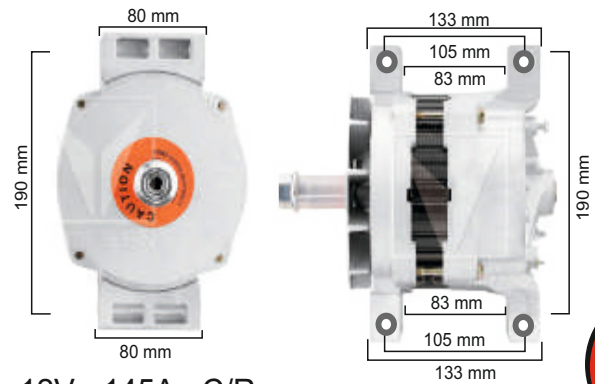

12V - 145A - C/R  
Universal pata cruzada



**30108** 12V - 220A **30063** 12V - 120A Tipo Delco

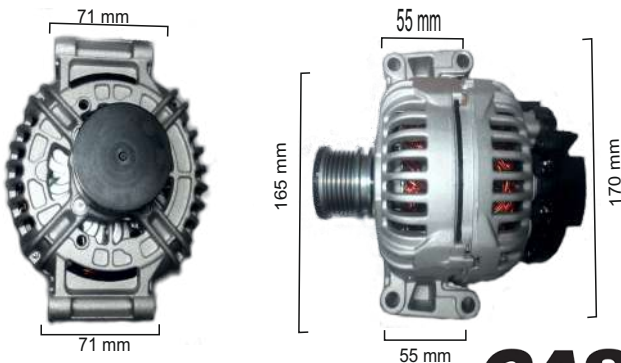

Cosechadora agricola Case



**30120**

Tipo Denso



New Holland TL70/80/90/100  
12V - 90A



**30111**

Tipo Delco

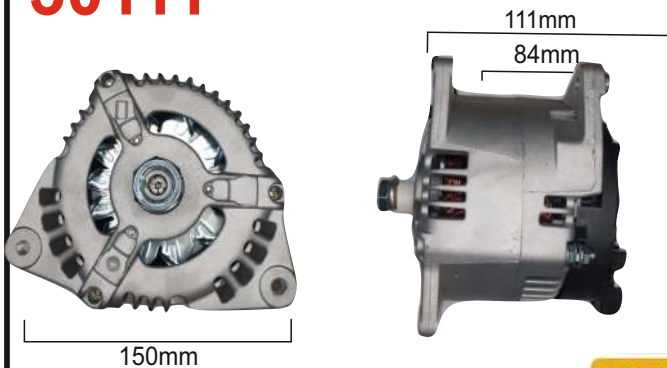

Caterpillar vial  
24V - 80A



**30121**

Tipo Denso

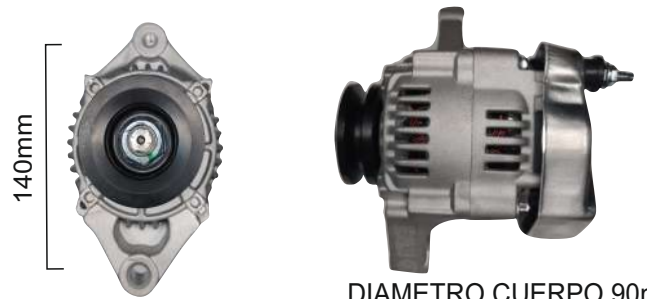

Autoelevadores Komatsu Kubota  
12V - 40A MINI ALTERNADOR



**30014**

Tipo Bosch

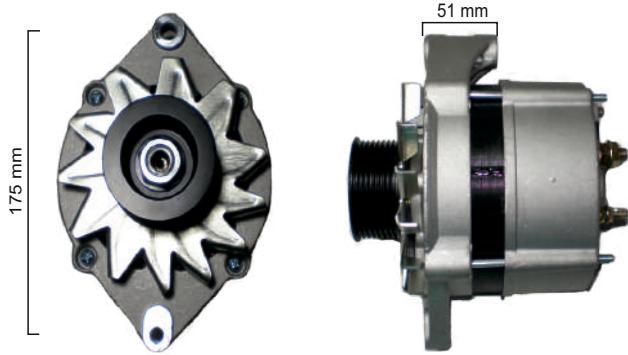

Ford Cargo 17220  
12V - 150A



**30015**

Tipo Bosch

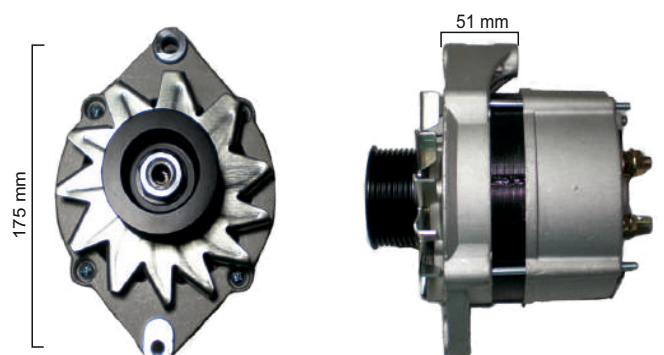

F100, Cummins  
12V - 105A



**30016**

Tipo Bosch

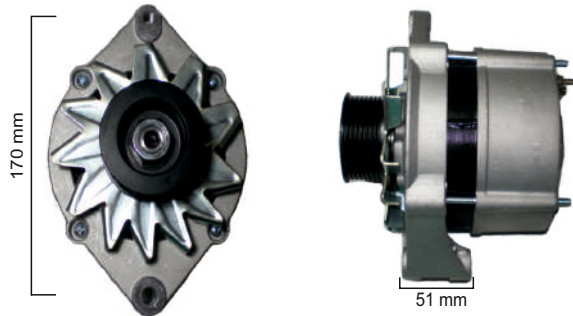

24V - 55A  
C/R Universal Cummins



**30060**

Tipo Bosch

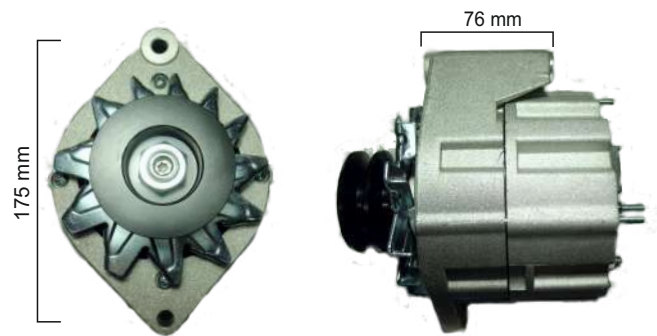

Ford Camión Cargo  
24V 60A C/R

Rotor:33060  
Estator:34060



**30061**

Tipo Bosch

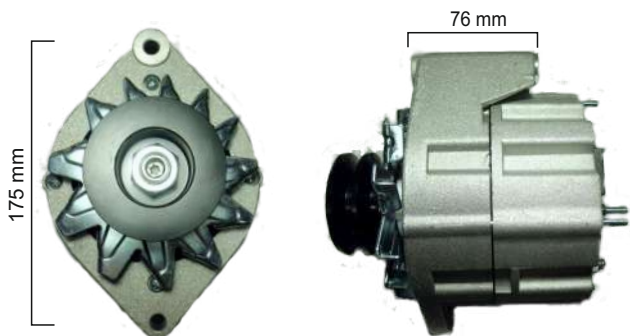

Ford Camión Cargo  
12V 80A C/R

Rotor:33061  
Estator:34061



**30103**

Tipo Bosch

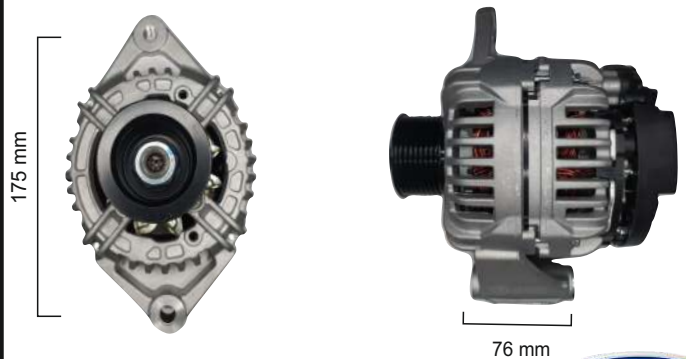

Ford Cargo 1722  
12V 90A



**30105**

Tipo Bosch

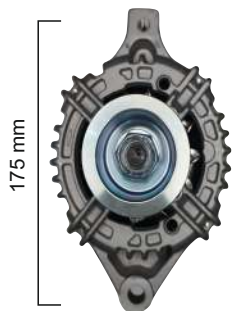

Ford F100 Cumins  
12V 90A



**30078**

Tipo Ford



Ford Ranger 2,2 - 3,2 D  
12V 110A C/R



**30095**

50mm Tipo Ford



FORD FOCUS FIESTA  
12V 90 C/R



**30094**

Tipo Ford



FOCUS FIESTA Polea  
con manchón 12v 120A C/R

Rotor:33094  
Estator:34094



**30119**

Tipo Bosch



FORD TRANSIT  
12V 150A C/R



**30071**

Tipo Bosch

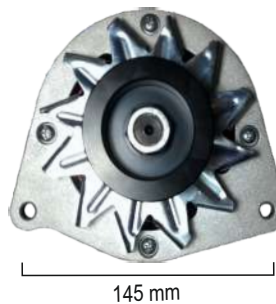

Ford Ranger Maxion  
12V 110A Con Depresor



**30116**

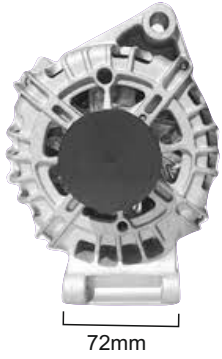

72mm



55mm



FOCUS, FORD  
12V 120A

**30135**



73mm



73mm



FOCUS, FIESTA, ECO SPORT  
12V 150A-POLEA CON EMBRAGUE

**30098**

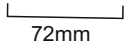

72mm

40mm TIPO BOSCH

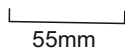

55mm



FORD FIESTA KA  
12V 900A

**30110**

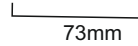

73mm

TIPO BOSCH

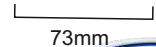

73mm



KUGA  
12V 150A



**30011**

Tipo Valeo



P 206, P 307 full Nafta/Diesel  
12V 120 amp. C/R.



**30031**

Tipo Valeo

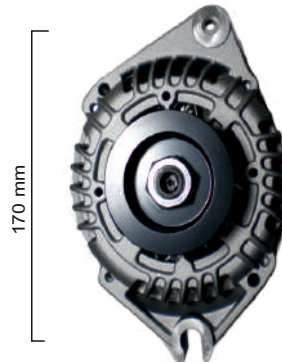

P306, P405, Nafta, Diesel  
12V - 90A - Pata con ranura

Rotor:33031  
Estator:34031



**30057** CL 12

Tipo Valeo

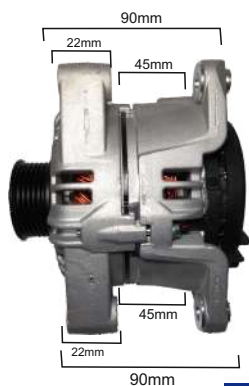

P206 P306 Partner  
12V 120A. Polea cricket.



**30058** CL 8

Tipo Valeo

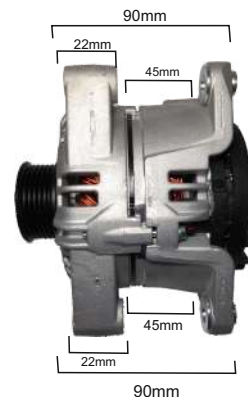

P206 P306 Partner  
12V 90A.



**30067**

Tipo Valeo

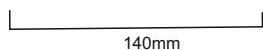

P2008 P3008 Partner ful  
12V 150A.



**30003**

Tipo Bosch

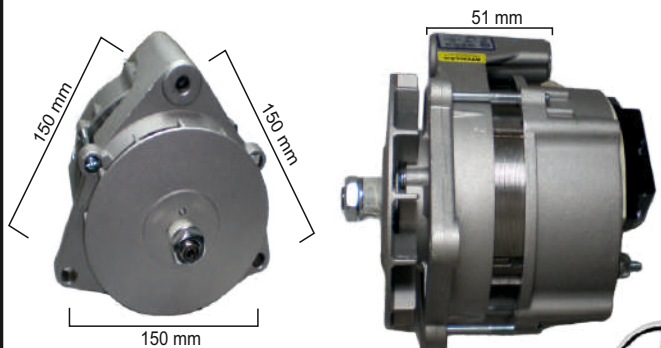

12V - 120A  
C/R MB 1518



**30017**

Tipo Bosch

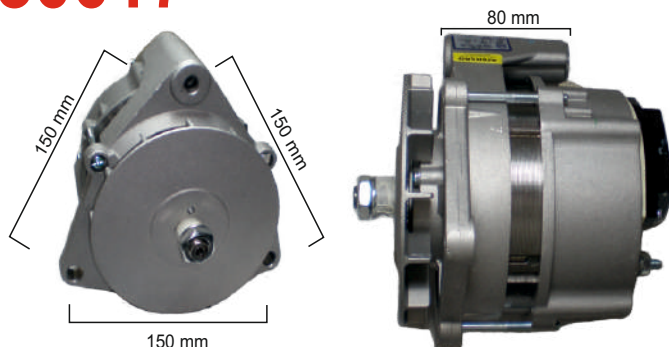

12V - 60A  
C/R MB 1518



**30019**

Tipo Bosch

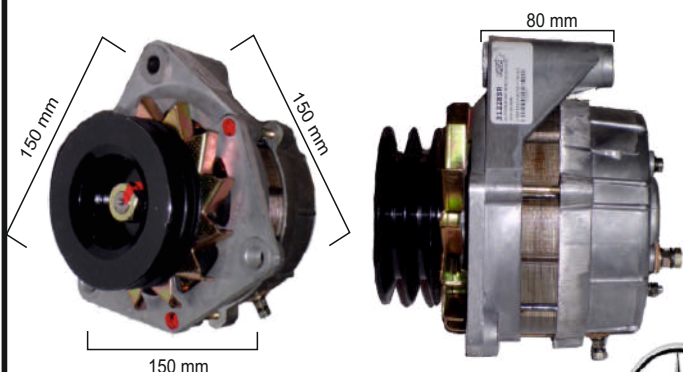

MB 1114, 1518, 1620, 1633  
24V - 60A - C/R



**30047**

Tipo Bosch

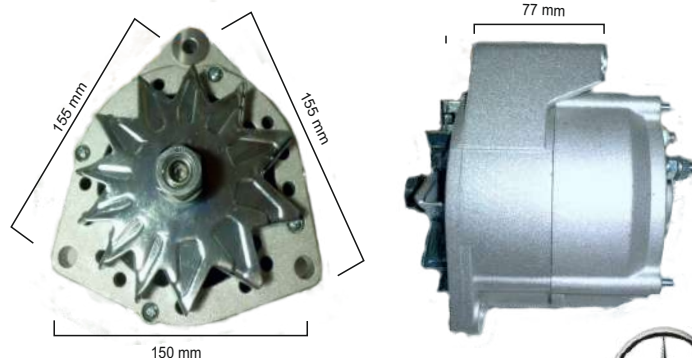

MB 1518, 1620  
12V 90A C/R - Reforzado

Rotor:33047  
Estator:34047



**30055**

Tipo Bosch

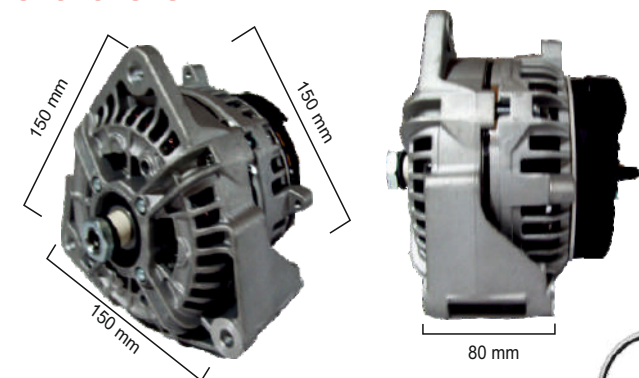

Ruleman grande 62mm  
Similar 30000 24V 100A C/R | 5 PIN



**30063**

Tipo Bosch

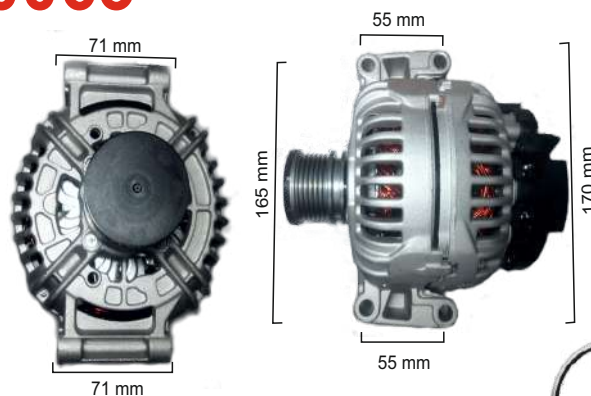

Sprinter  
12V 120A C/R



**30000 30001** 24V  
**30102** 12V

Tipo Bosch

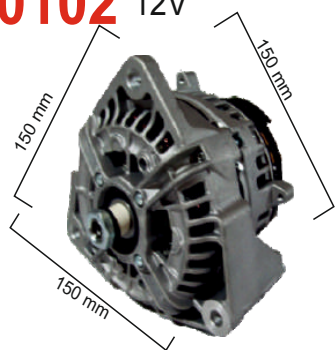

MB Electrónico todos  
100A - C/R inteligente

Rotor:33000  
Estator:34000

**30080** 12V 150A C/R  
**30081** 24V 150A C/R

Tipo Bosch

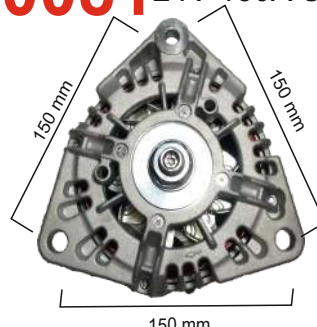

Tipo agrícola  
MB Universal

Rotor:33080  
Estator:34080

Rotor:33081  
Estator:34081

**3830001**

Tipo Bosch

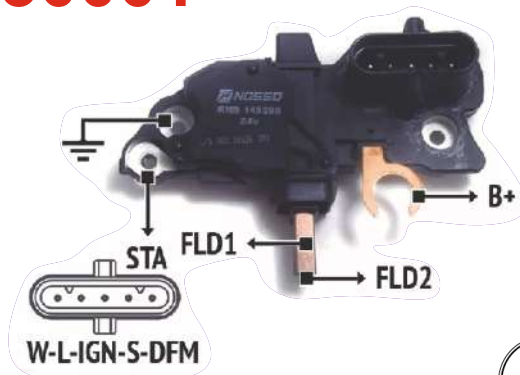

SIMIL RNB 145298  
24V 5P-ORO 1568

Mercedes-Benz

**30068**

Tipo Valeo

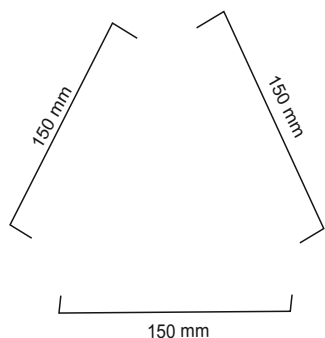

Sprinter  
12v 150A



**30069**

Tipo Valeo

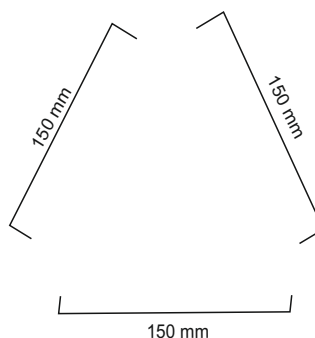

Sprinter  
12v 180A



**30073**

Tipo Valeo

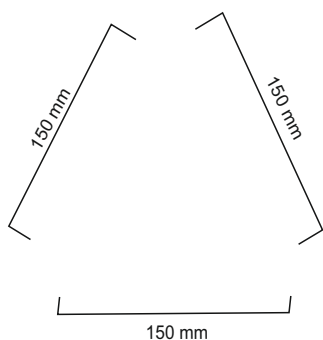

Sprinter  
12v 220A



**30074**

Tipo Valeo

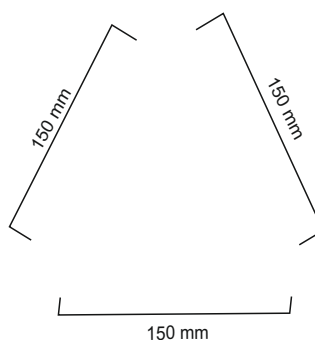

Sprinter  
12v 250A



**30140** F000BL0769

Tipo Bosch

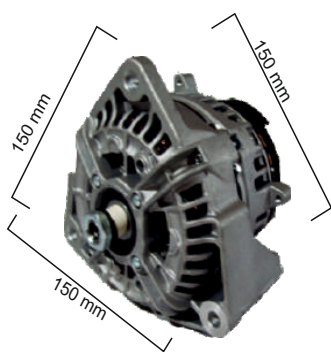

MB Electrónico todos  
24v-100A - C/R inteligente

Rotor:3330140  
Estator:3430140



**30112**

Tipo Mareli



Palio Siena, Strada  
12V - 85A



**30100**

Tipo Bosch

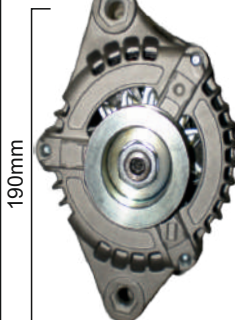

Ducato Iveco  
12v 140A



**30013**

Tipo Bosch

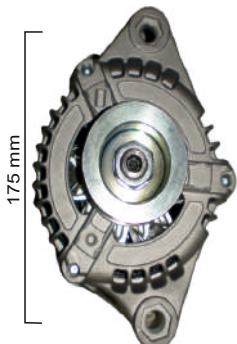

Palio, Siena  
12V - 80A

Rotor:33013  
Estator:34013



**30043**

Tipo Bosch

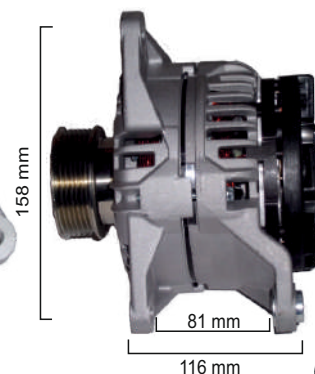
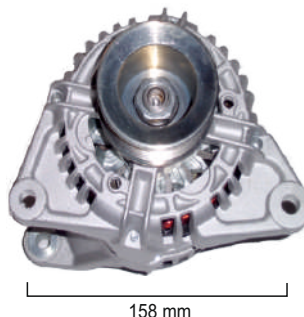

Fiat Iveco Daily  
12V - 90A



**30064**

Tipo Denso

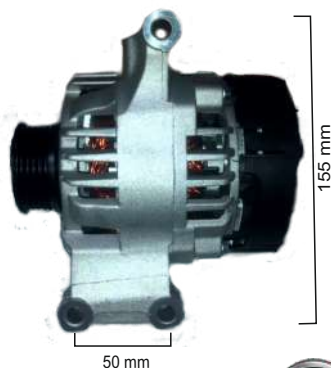
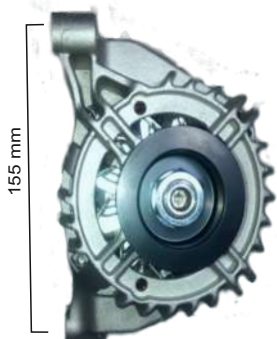

Palio, Siena  
12V 90A C/R

Rotor:33064  
Estator:34064



**30065**

Tipo Bosch

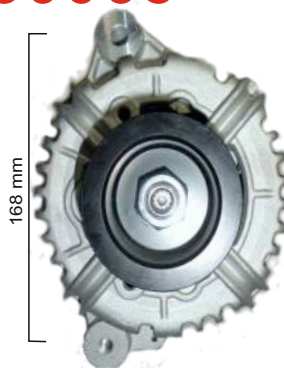

Euro Cargo Iveco  
24V 90A C/R

Rotor:33065  
Estator:34065



**30092**

Tipo Bosch



FIAT CAMIÓN  
24V 55A C/R

**30093**

Tipo Bosch



FIAT CAMIÓN  
24V 70 C/R

**30099**

Tipo Valeo

mm

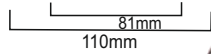

DUCATO-IVECO  
12V 180

**30014**

Tipo Bosch

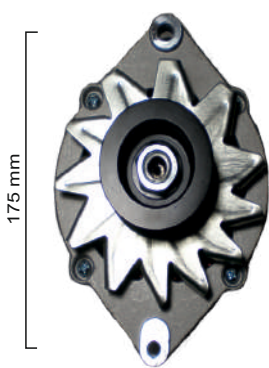

Cargo 17220  
12V - 105A

**30015**

Tipo Bosch

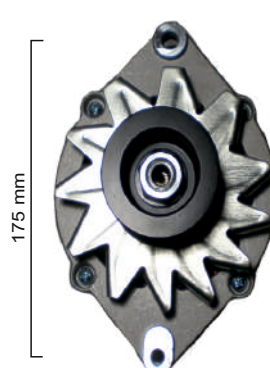

, Cummins  
12V - 105A

**30016**

Tipo Bosch

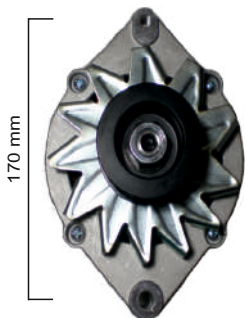

24V - 55A  
C/R Universal Cummins

**30101**

Tipo Bosch



GOL, POLO, SAVEIRO  
12V 120A

**30060**

Tipo Bosch

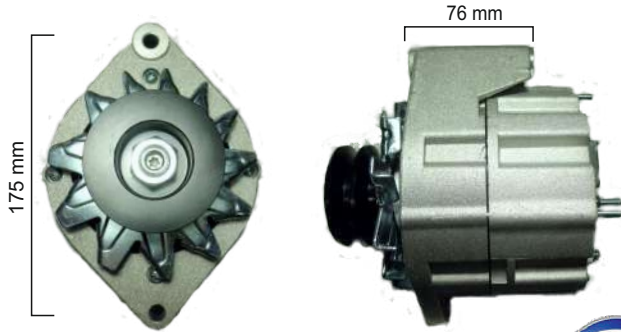

Camión Cargo  
24V 60A C/R

Rotor:33060  
Estator:34060



**30061**

Tipo Bosch

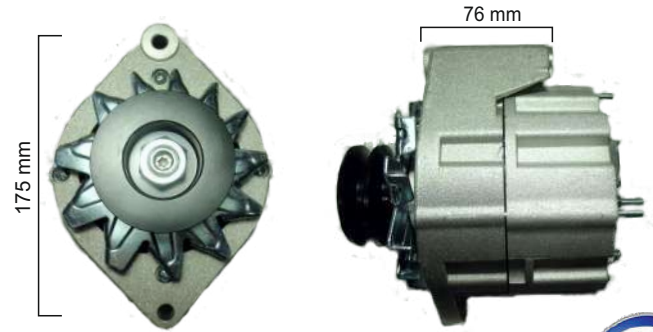

Camión Cargo  
12V 80A C/R

Rotor:33061  
Estator:34061



**30103**

Tipo Bosch

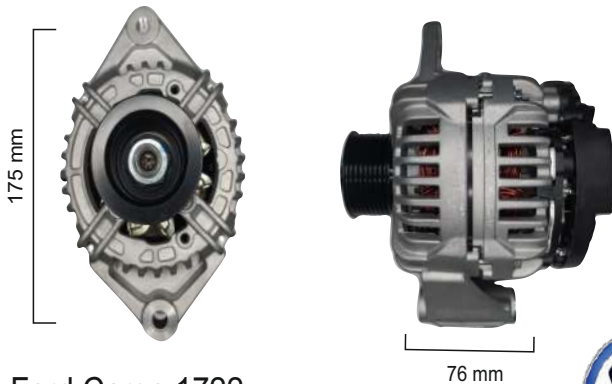

Ford Cargo 1722  
12V 90A



**30105**

Tipo Bosch

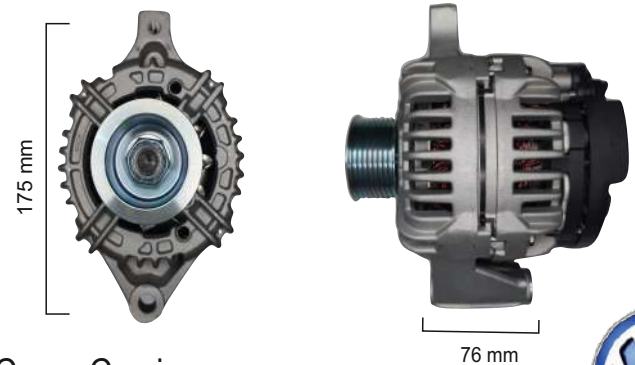

Cargo Cumins  
12V 90A



**30104**

Tipo Bosch



Camión VW 13180  
12V 90A



**30049**

Tipo Bosch



Gol, Saveiro  
12V - 90A





**30076**

Tipo Valeo

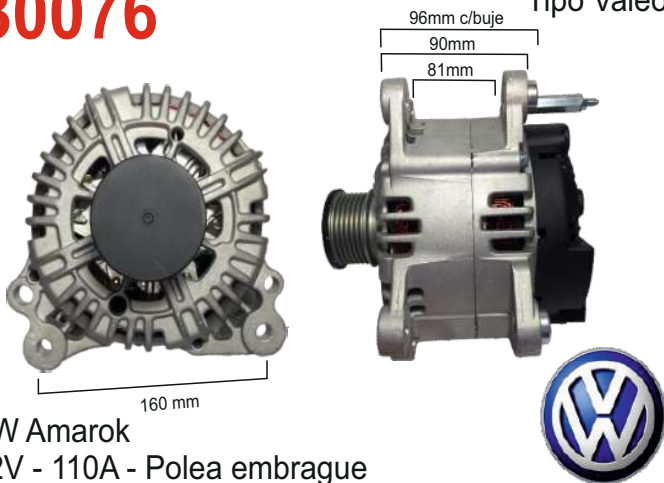

**30032**

Tipo Bosch

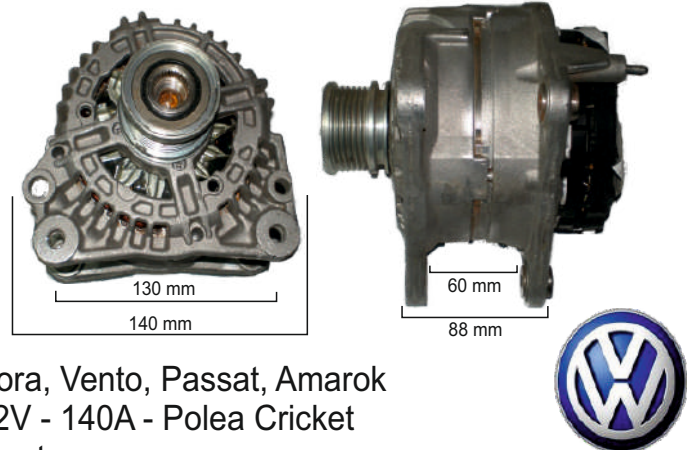

**30033**

Tipo Bosch

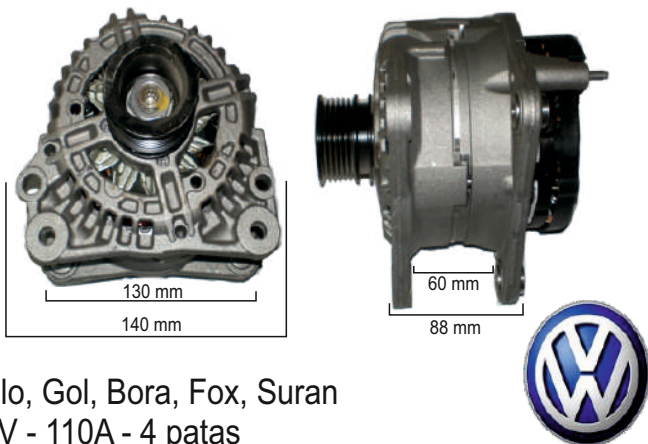

**30066**

Tipo Bosch



**30004**

Tipo Bosch

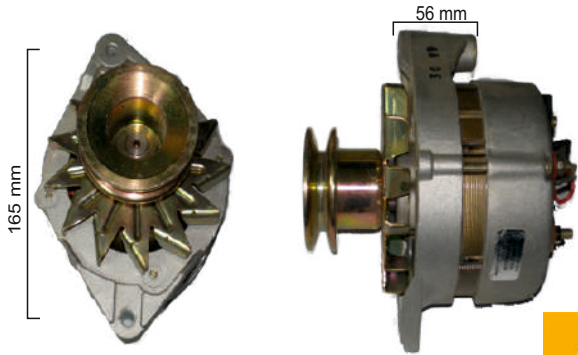

R19, R11, Trafic  
12V - 55A



**30026 - 30028**

Tipo Valeo

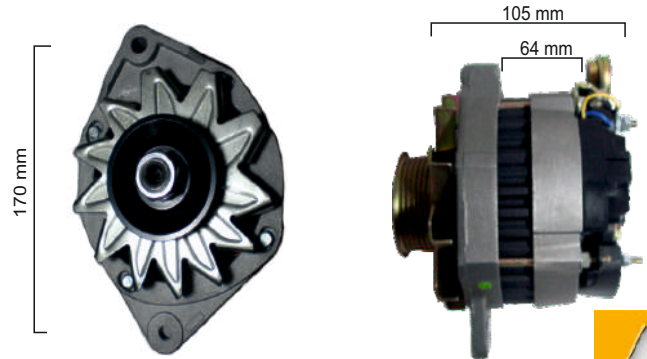

R18, Trafic, R19 - Tapa chapa  
12V - 70A



**30030** VMV

Tipo Valeo

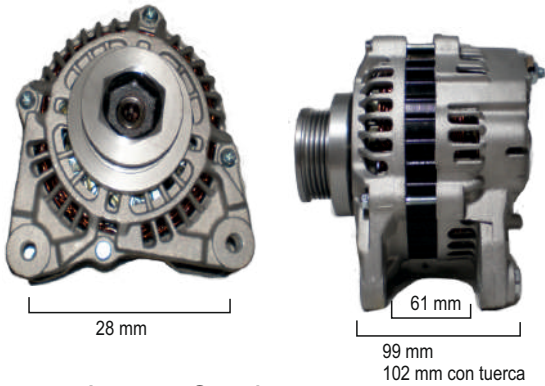

Kangoo, Logan, Sandero  
12V - 110A - Polea goma



**30106**

Tipo Valeo

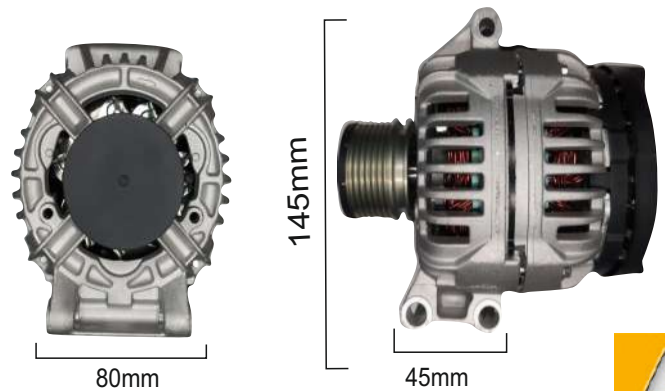

Megane Scenic  
12V - 100A -



**30124**

Tipo Valeo

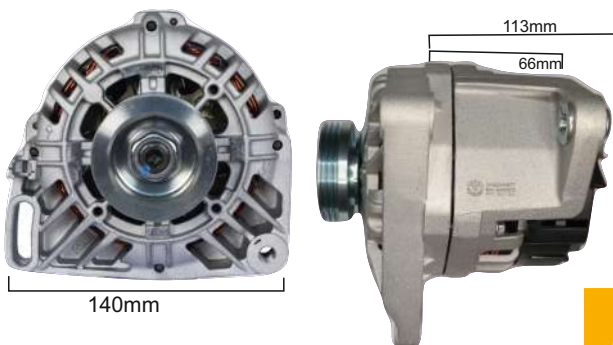

Kangoo, Clio  
12v 90A



**30128**

Tipo Valeo

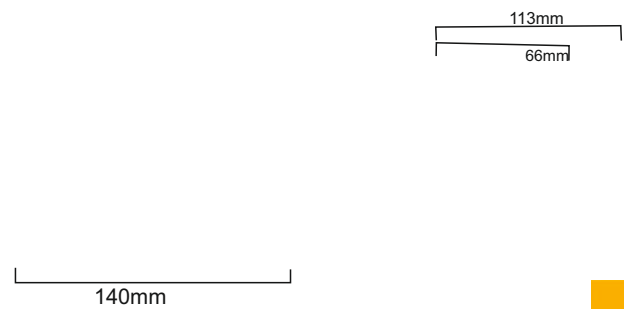

Sandero Logan  
12v 95A



**30009 - 30020**

Tipo Delco

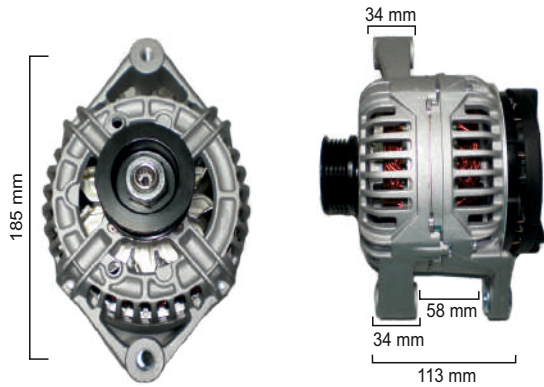

Chevrolet Corsa Nafta  
12V - 110A - C/R



**30029**

Tipo Hitachi

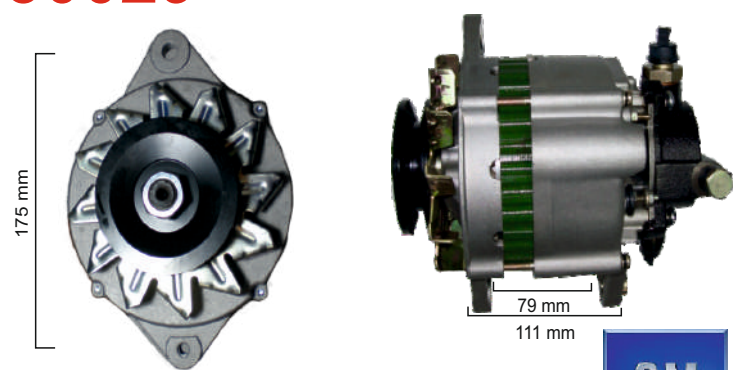

Corsa Diesel c/depresor  
12V - 110A



**30062**

Tipo Bosch

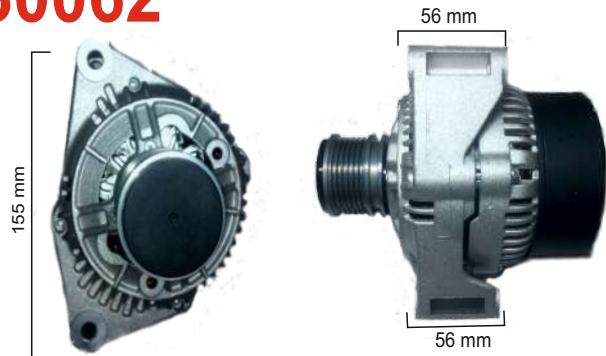

Polea Crique S10 **NUEVA**  
12V 90A C/R



**30077**

Tipo Valeo

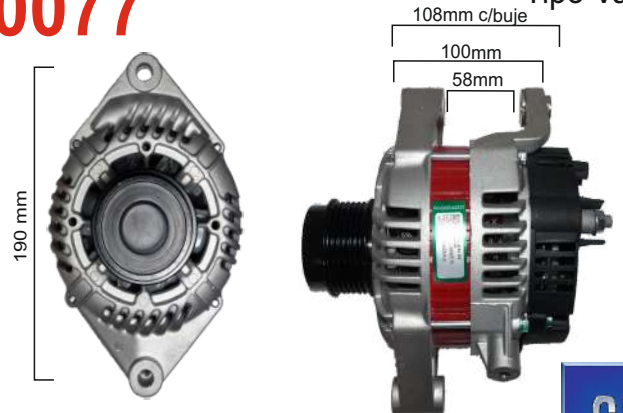

Chevrolet S10, MVM 2000 hasta 2012  
12V - 110A - Polea con embrague



**30114**

TIPO DELCO



ONIX PRISMA  
12V 80A



**30117**

Tipo Bosch



**Volvo Fh12**  
24v 110A

**30090**

Tipo BOSCH

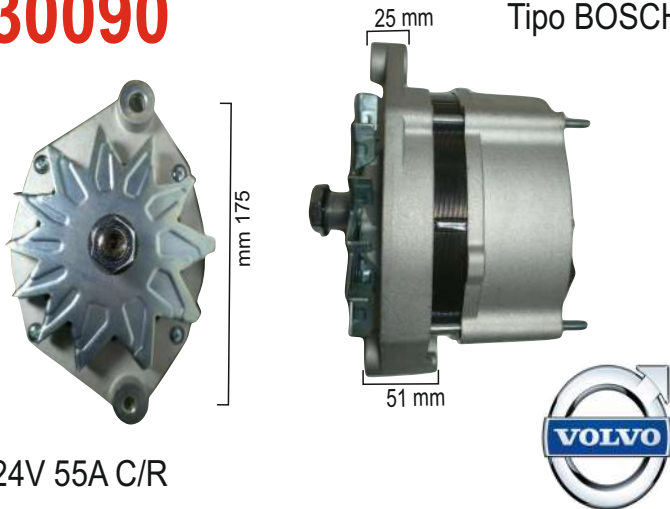

24V 55A C/R

**30109**

Tipo BOSCH

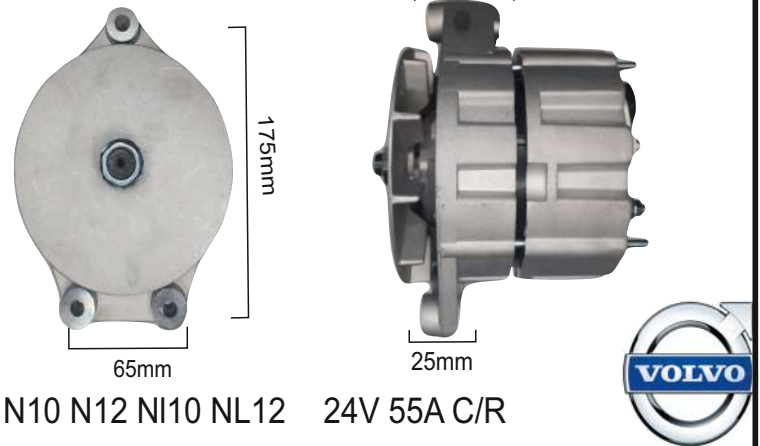

N10 N12 NI10 NL12 24V 55A C/R

**30072**

Tipo Nipondenso

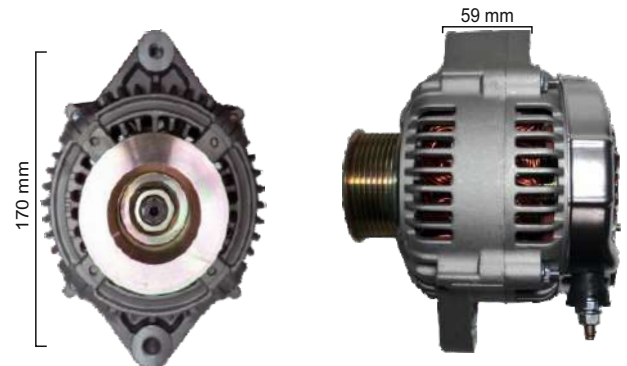

**Jhon Deere**  
12V 120 amp. c/ reg. incorporado.



**30037**

Tipo Hitachi

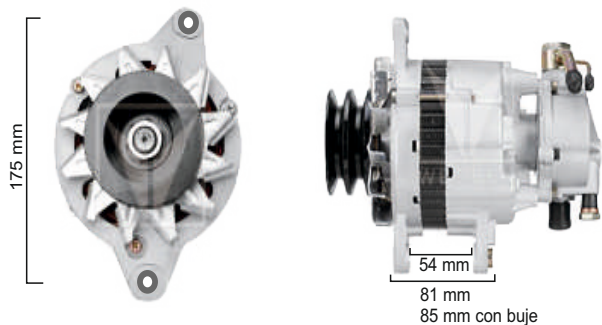

Isuzu Pick Up - C/R  
12V - 70A - Con depresor

**ISUZU**

**30034**

Tipo Hitachi

Universal c/depresor  
24v-90A

**ISUZU**

**30035**

Tipo Hitachi

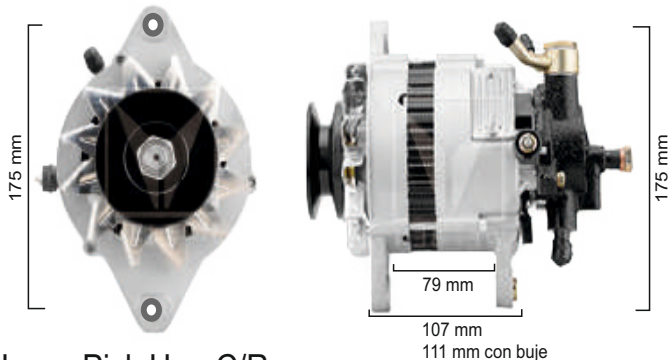

Isuzu Pick Up - C/R  
12 - 70A - Con depresor

**ISUZU**

**30036**

Tipo Hitachi

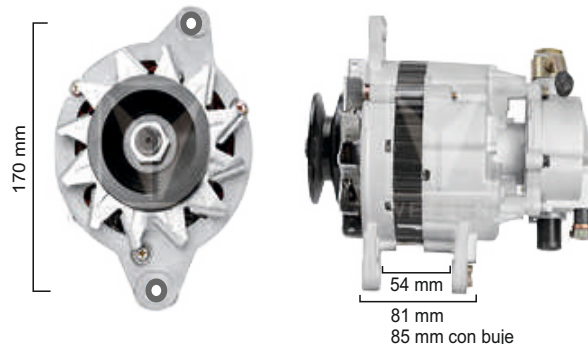

Isuzu Pick Up - C/R  
12V - 70A - Con depresor

**ISUZU**

**30021**

Tipo Mitsubishi

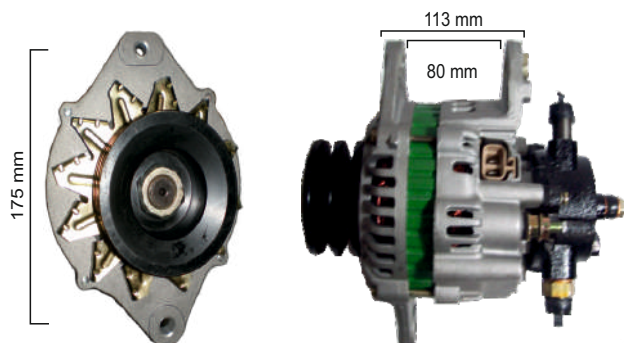

L300 c/depresor  
24V - 60A

**MITSUBISHI**  
MOTORS

**30040**

Tipo Bosch

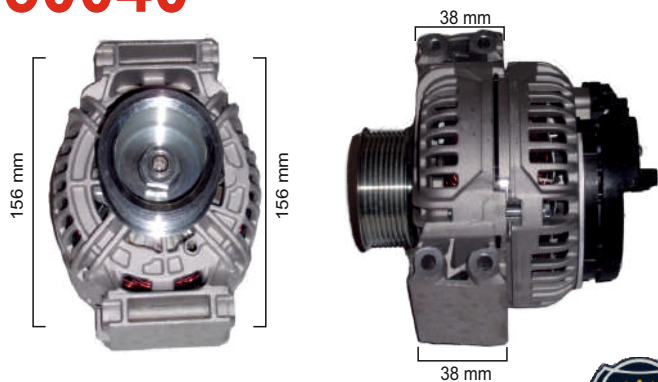

Scania Serie P  
24V - 80A



**30027**

Tipo Bosch

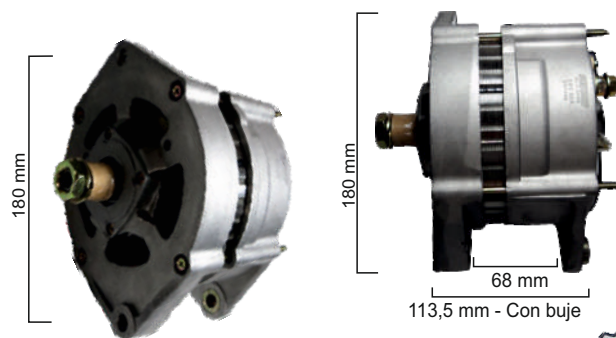

Scania 112  
24V - 55A

Rotor:33027  
Estator:34027



**30041**

Tipo Delco

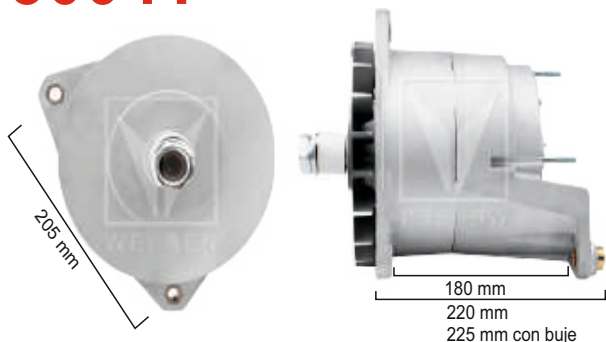

24V - 140A - C/R  
Scania - Línea Buses



**30096**

Tipo Bosch



Scania 112  
24V-60A



**30113**

Tipo BOSCH

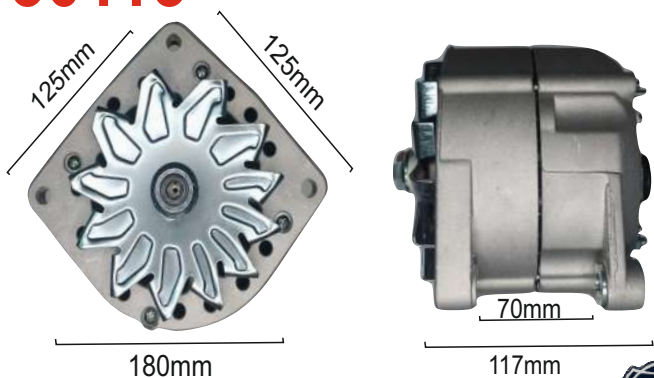

Scania Camion  
24V 65A C/R



**30091**

Tipo Bosch

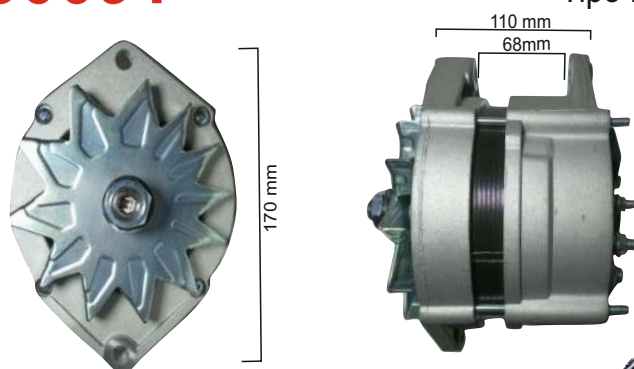

Scania 112  
24V - 55A C/R



**30050**

Tipo Bosch



Toyota 2, 5, 3, 00  
12V - 90A



**30023/24/25**

Tipo Nipondenso

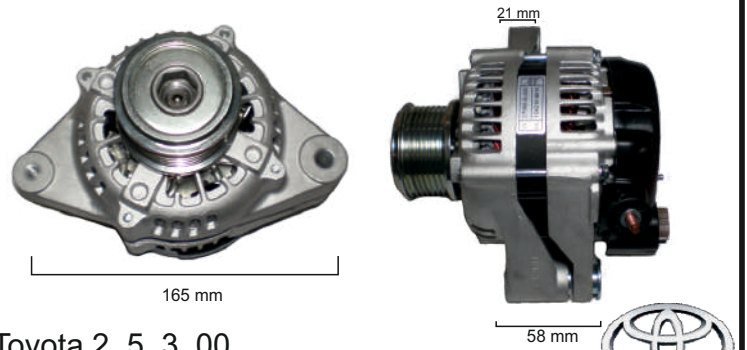

Toyota 2, 5, 3, 00  
2005>  
12V - 70A - C/R

30023 VMV 70A  
30024 VMV 90A  
30025 VMV 110A

Rotor:33023  
Estator:34023



**30022**

Tipo Nipondenso

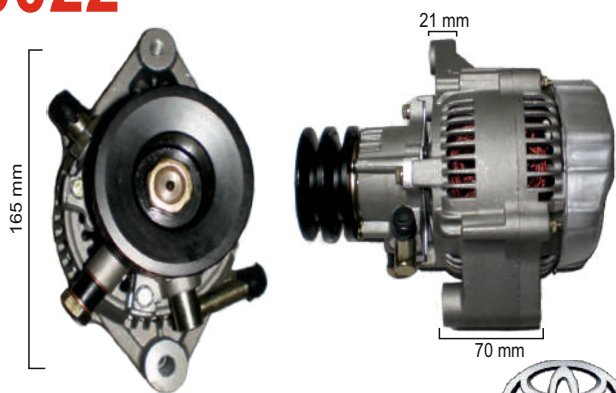

Hilux hasta 2005 c/depres. adelante  
12V - 80A

Rotor:33022  
Estator:34022



**30118**

Tipo Denso

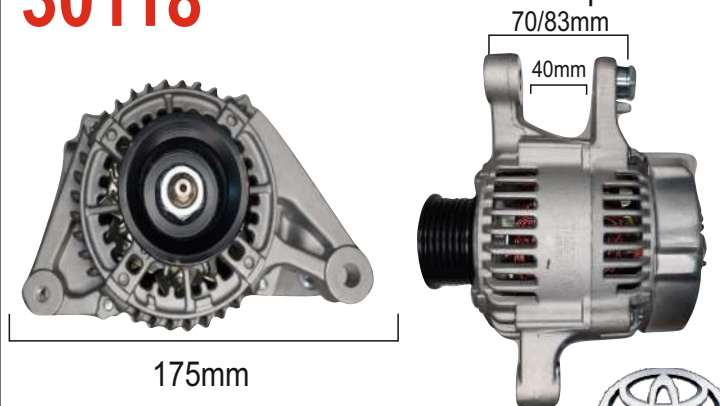

Corolla 1.8  
12V - 90A



**30075**

Tipo Nipondenso



Toyota Hilux 2015 en adelante  
12V - 100A



**30085**

Tipo Bosch



Toyota Hilux 2015 en adelante  
12V - 100A



LINEA J (VIOLETA)

**VMV**  
IMPORTACIONES

**ALTERNADORES 20A**

**30086**

Tipo Denso  
70/83mm  
40mm

175mm

Jeep Renegade  
12V - 100A



**30126**

Tipo Denso  
70/83mm  
40mm

175mm

Honda HRV  
12V-135A



**30127**

Tipo Denso  
70/83mm  
40mm

175mm

Honda ERV  
12V - 140A





**3530001TD**

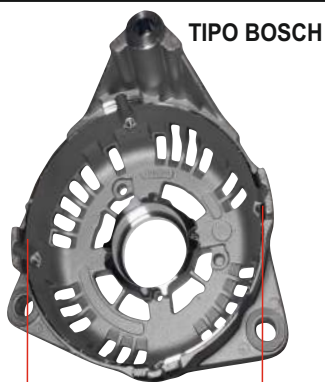
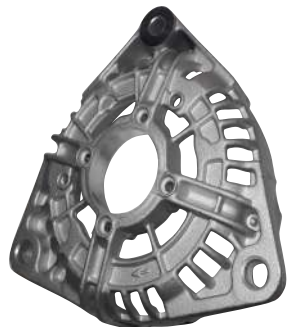

TIPO BOSCH

141 mm

APLICABLE  
30001



TAPA DELANTERA MB  
1624 24V 80A ELECTRÓNICO

**3630001TT**

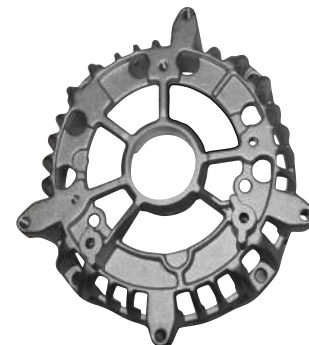
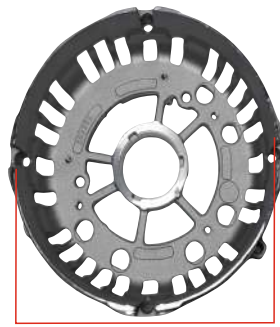

TIPO BOSCH

141 mm

APLICABLE  
30001



TAPA TRASERA MB  
1624 24V 80A ELECTRÓNICO

**3530000TD**

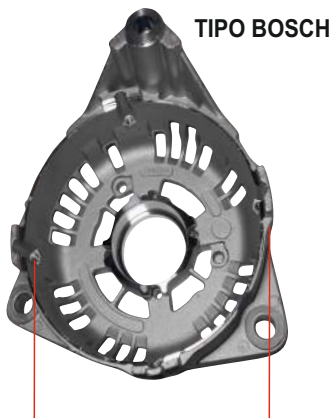
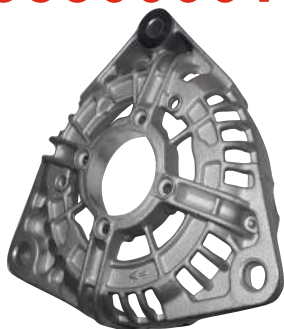

TIPO BOSCH

147 mm

APLICABLE  
30000



TAPA DELANTERA MB  
1624 24V 110A ELECTRÓNICO

**3630000TT**

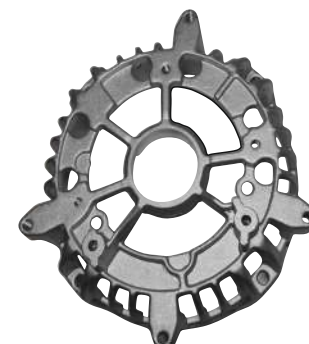
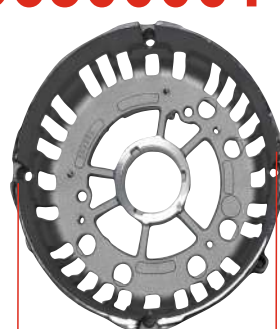

TIPO BOSCH

147 mm

APLICABLE  
30000



TAPA TRASERA MB  
1624 24V 110A ELECTRÓNICO

**3530055TD**

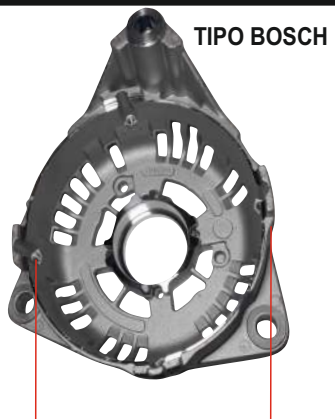

TIPO BOSCH

150 mm

APLICABLE  
30080/30081  
30055



TAPA DELANTERA MB  
1624 150A ELECTRÓNICO

**3630055TT**

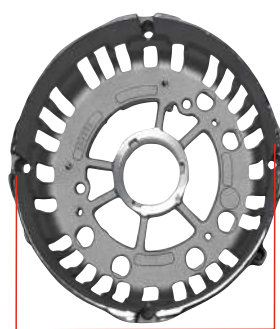

TIPO BOSCH

150 mm

APLICABLE  
30080/30081  
30055



TAPA TRASERA MB  
1624 150A ELECTRÓNICO

**3530140TD**

TIPO BOSCH

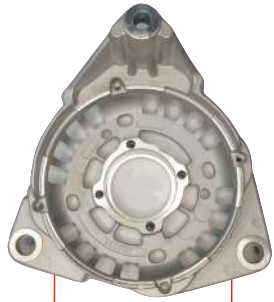

135 mm

TAPA DELANTERA MB  
1624 24V 80A ELECTRÓNICO

APLICABLE  
30140



**3730140TT**

TAPA C/DIODOS

TIPO BOSCH

**3630140TT**

TAPA SOLA

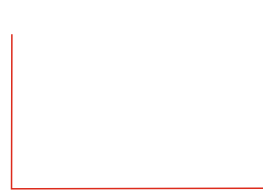

TAPA TRASERA MB  
1624 24V 80A ELECTRÓNICO

APLICABLE  
30140



**3530007TD**

TIPO LUCAS

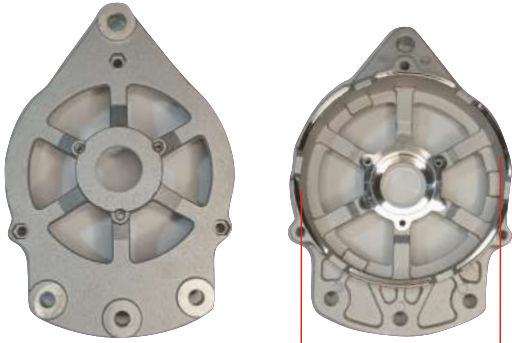

124 MM

TAPA DELANTERA UNIVERSAL

APLICABLE  
30007-30070



**3630007TT**

TIPO LUCAS

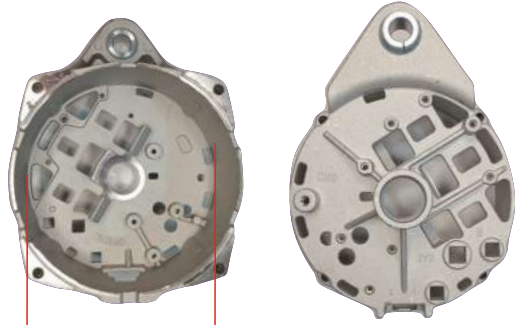

124 MM

TAPA TRASERA UNIVERSAL

APLICABLE  
30007-30070



**3530005TD**

TIPO DELCO REMY

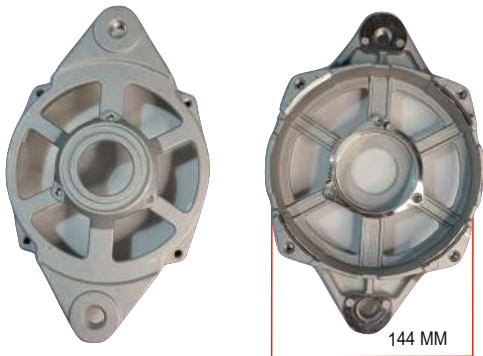

144 MM

TAPA DELANTERA UNIVERSAL TIPO  
DELCO REMY 12V-150A

APLICABLE  
30005-30018



**3630005TT**

TIPO DELCO REMY

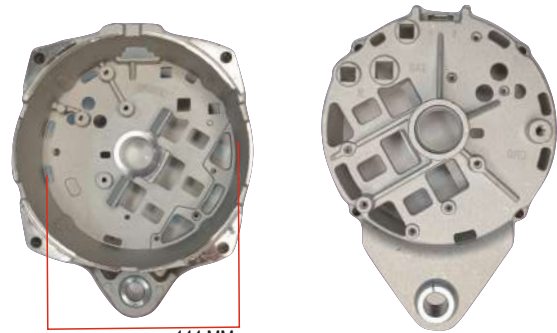

144 MM

TAPA TRASERA UNIVERSAL TIPO  
DELCO REMY 12V-50A

APLICABLE  
30005-30018



**3530013TD**

TIPO MARELLI

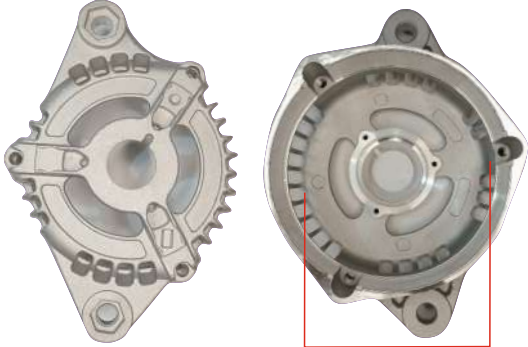

130 MM

TAPA DELANTERA PALIO, SIENA  
12V-70A

APLICABLE  
30013



**3630013TT**

TIPO MARELLI

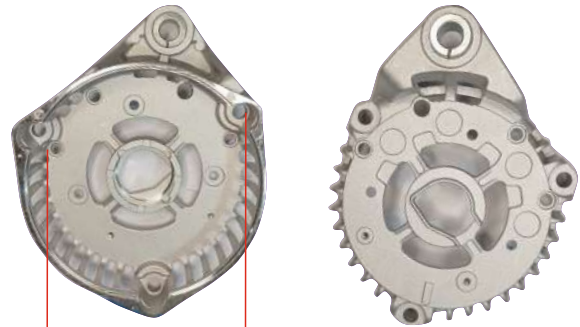

130 MM

TAPA TRASERA PALIO, SIENA  
12V-70A

APLICABLE  
30013



**3530064TD**

TIPO MARELLI



118 MM

TAPA DELANTERA MARELLI  
PALIO, SIENA 12V-90A

APLICABLE  
30064



**3630064TT**

TIPO MARELLI

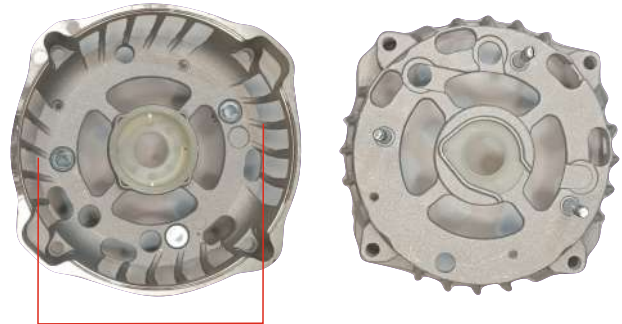

118 MM

TAPA TRASERA MARELLI  
PALIO, SIENA 12V-90A

APLICABLE  
30064



**3530065TD**

TIPO BOSC

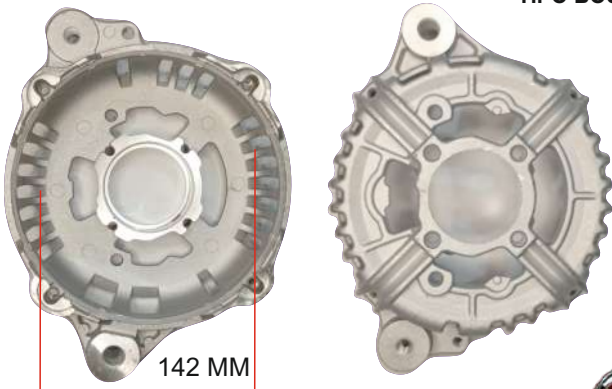

142 MM

TAPA DELANTERA  
FIAT IVECO CARGO 24V-90A

APLICABLE  
30065



**3630065TT**

TIPO BOSC

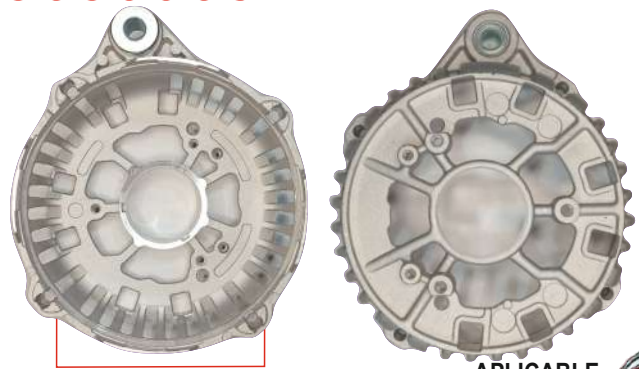

APLICABLE  
30065

TAPA TRASERA  
FIAT IVECO CARGO 24V-90A



**3530014TD**

TIPO BOSCH

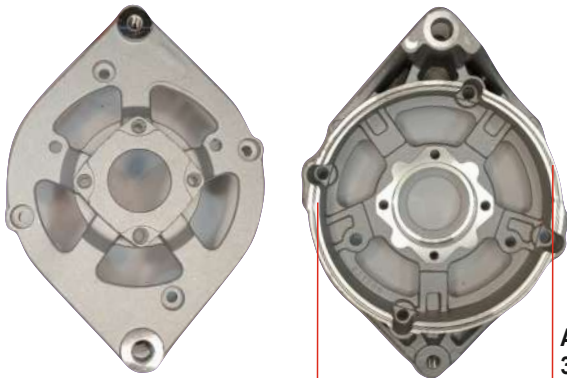

TAPA DELANTERA FORD CUMING  
12V-50A

124 MM

APLICABLE  
30014/15/16



**3630014TT**

TIPO BOSCH

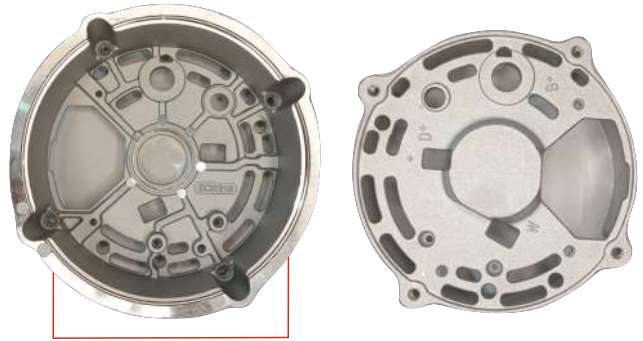

124 MM

TAPA TRASERA FORD CUMING  
12V-50A

APLICABLE  
30014/15/16



**3530060TD**

TIPO BOSCH

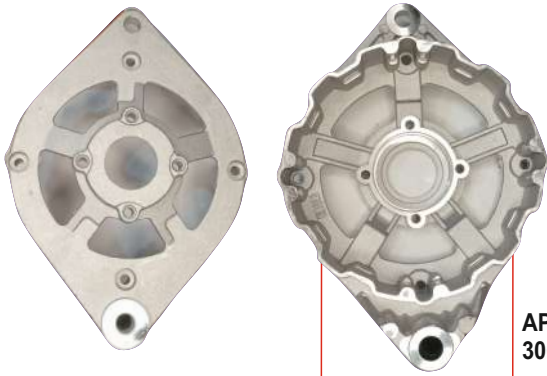

TAPA DELANTERA FORD CUMING  
24V-90A

125 MM

APLICABLE  
30060-30061



**3630060TT**

TIPO BOSCH

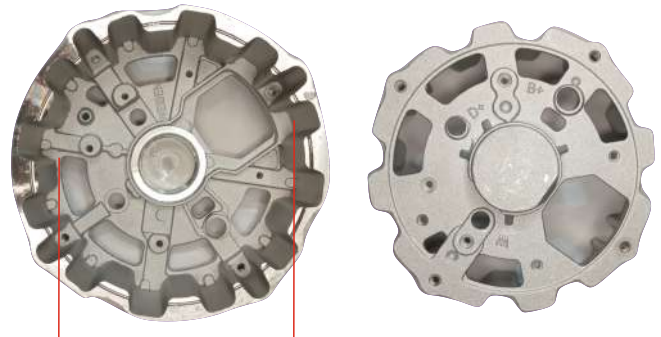

125 MM

TAPA TRASERA FORD CUMING  
24V-90A

APLICABLE  
30060-30061



**3530095TD**

TIPO VALEO

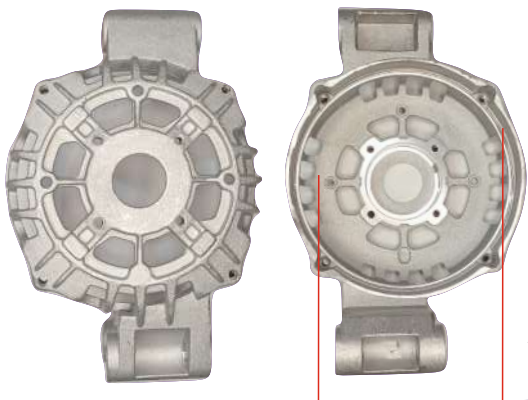

TAPA DELANTERA  
FORD FIESTA, ECO SPORT 12V-90A

APLICABLE  
30095



**3730095TT**

TIPO VALEO

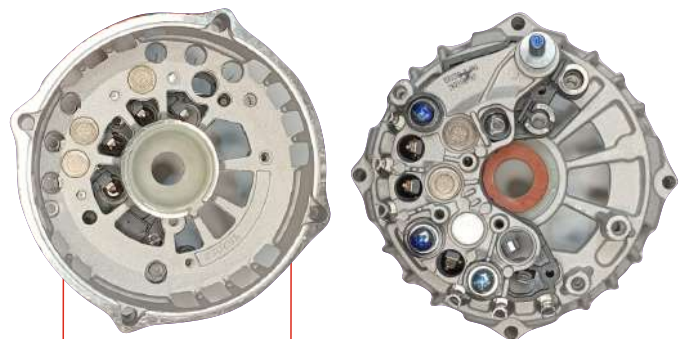

TAPA TRASERA CON PLACA DIODO  
FORD FIESTA, ECO SPORT 12V-90A

APLICABLE  
30095



**3530022TD**

TIPO NIPONDENSO

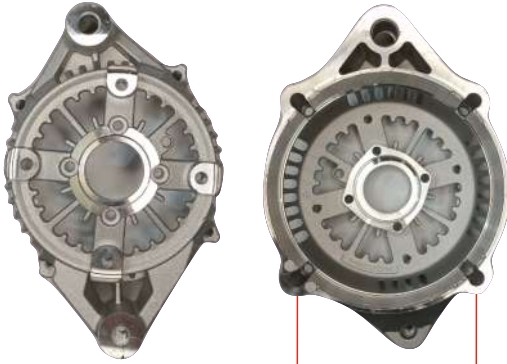

APLICABLE  
30022



**TOYOTA**

TAPA DELANTERA HILUX CON DEPRESOR  
ADELANTE HASTA 2005 12V-80A

118 MM

**3630022TT**

TIPO NIPONDENSO

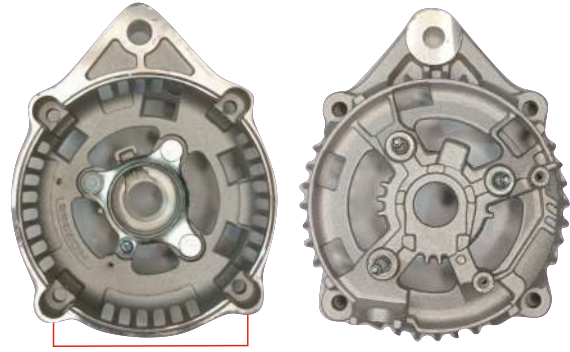

APLICABLE  
30022



**TOYOTA**

TAPA TRASERA HILUX CON DEPRESOR  
ADELANTE HASTA 2005 12V-80A

118 MM

**3530023TD**

TIPO NIPONDENSO

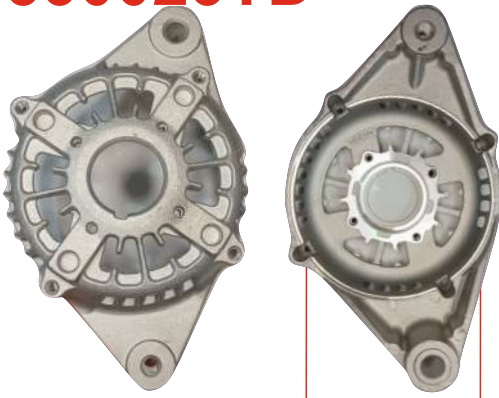

APLICABLE  
30023



**TOYOTA**

TAPA DELANTERA HILUX DESDE 2005  
12V-80A

111 MM

**3630023TT**

TIPO NIPONDENSO

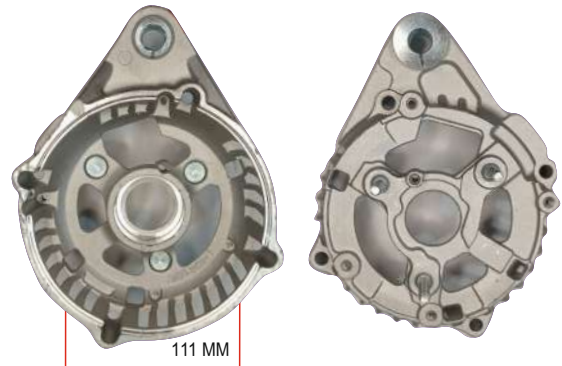

APLICABLE  
30023



**TOYOTA**

TAPA TRASERA HILUX DESDE 2005  
12V-80A

111 MM

**3530027TD**

TIPO BOSCH

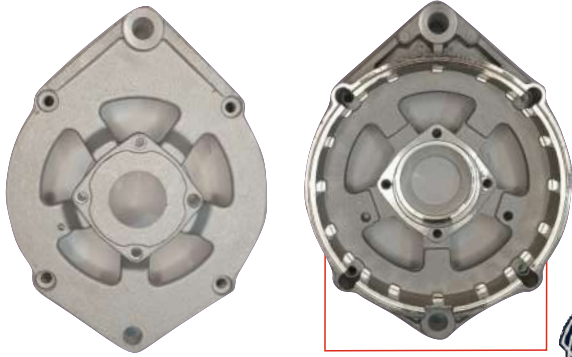

TAPA DELANTERA SCANIA 112  
24V-90A

141 MM

APLICABLE  
30027



**3630027TT**

TIPO BOSCH

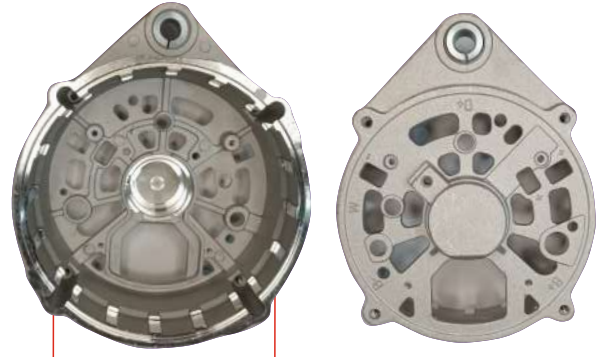

TAPA TRASERA SCANIA 112  
24V-90A

141 mm

APLICABLE  
30027



**3530040TD**

TIPO BOSCH

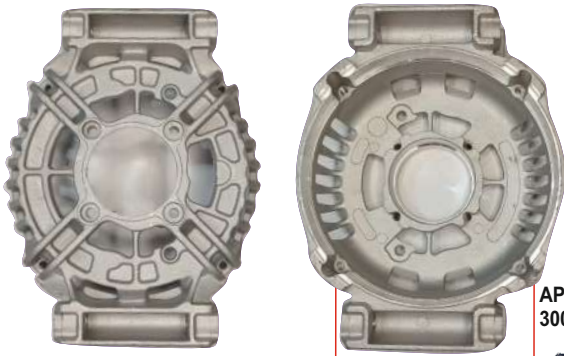

TAPA DELANTERA SCANIA 113  
24V-90A

137 MM

APLICABLE  
30040



**3630040TT**

TIPO BOSCH



TAPA TRASERA SCANIA 113  
24V-90A

137 MM

APLICABLE  
30040



**3530031TD**

TIPO VALEO



128 MM

APLICABLE  
30031



TAPA DELANTERA PEUGEOT 405-306  
12V-90A

**3730031TT**

TIPO VALEO



128 MM

APLICABLE  
30031



TAPA TRASERA PEUGEOT 405-306  
12V-90A CON DIODOS

**3530058TD**

TIPO VALEO



128 MM

APLICABLE  
30058



TAPA DELANTERA PEUGEOT 206  
PARTNER C18 12V-90A

**3730058TT**

TIPO VALEO

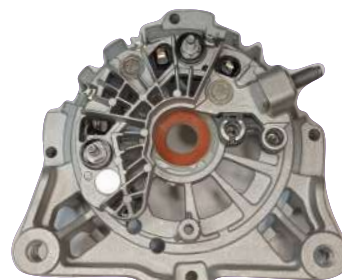
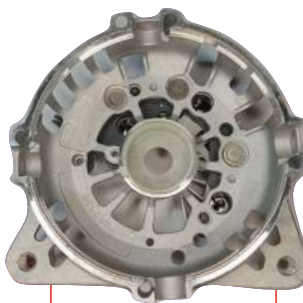

128 MM

APLICABLE  
30058



TAPA TRASERA PEUGEOT 206  
PARTNER C18 12V-90A CON DIODOS

**3530114TD**

TIPO DELCO

TAPA DELANTERA COBAL  
ONIX PRISMA  
12V-80A

APLICABLE  
30114



**3730114TT**

TIPO DELCO

TAPA TRASERA COBAL  
ONIX PRISMA C/DIODOS  
12V-80A

APLICABLE  
30114





DN: Diámetro núcleo - LT: Largo total - CMP: Cant. masas polares - ANS: Ancho núcleo solo - ANV: Ancho con ventilador - LC: Largo colector - DC: Diámetro colector

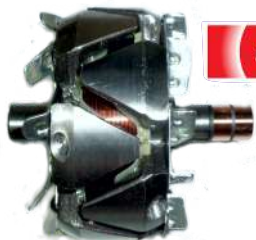

DENSO

**3330022/3025**

Nipondenso  
Hilux hasta 2005 - Con depresor

DN:92mm CMP:12 ANV:75mm DC:15mm  
LT:129mm ANS:51mm LC:24mm

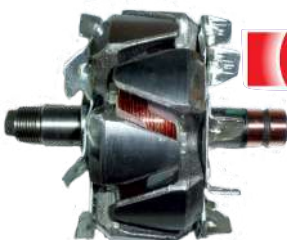

DENSO

**330023/3026**

Nipondenso  
Hilux desde 2005 hasta 2015

DN:87mm CMP:12 ANV:75mm DC:15mm  
LT:142mm ANS:49mm LC:23mm



MAGNETI  
MARELLI

**3330013/33013**

Marelli 12V - 100A  
Palio, Siena

DN:100mm CMP:12 ANV:80mm DC:17mm  
LT:159mm ANS:57mm LC:18mm

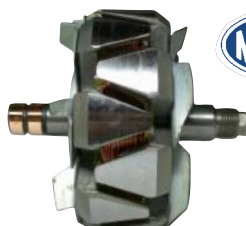

MAGNETI  
MARELLI

**3330094/33094**

MARELLI 12V - 120A  
Focus-Fiesta

DN:100mm CMP:16 ANV:73mm DC:15mm  
LT:147mm ANS:50mm LC:22mm



MAGNETI  
MARELLI

**3330064/33064**

MARELLI Palio, Siena 12V - 100A

DN:92mm CMP:12 ANV:78mm DC:16mm  
LT:153mm ANS:53mm LC:20mm



Delco  
Remy

**3330005/33005**

Delco 12V -150 A  
Universal Case Don Roque

DN:108mm CMP:12 ANV:--mm DC:30mm  
LT:214mm ANS:56mm LC:25mm



Delco  
Remy

**3330018/33018**

Delco 24V -190 A  
Universal Case Don Roque

DN:108mm CMP:12 ANV:--mm DC:30mm  
LT:214mm ANS:56mm LC:25mm

Delco  
Remy

**3330114**

Delco V12 -90 A  
Cobal Onix Prisma

DN:mm CMP: ANV:--mm DC:mm  
LT:mm ANS:mm LC:mm

DN: Diámetro núcleo - LT: Largo total - CMP: Cant. masas polares - ANS: Ancho núcleo solo - ANV: Ancho con ventilador - LC: Largo colector - DC: Diámetro colector



**3330061/33061**

Bosch 12V - 70A  
Ford Camión Cargo  **BOSCH**

DN:89mm CMP:12 ANV:--mm DC:28mm  
LT:166mm ANS:49mm LC:20mm



**3330060/33060**

Bosch 24V - 70A  
Ford Camión Cargo  **BOSCH**

DN:89mm CMP:12 ANV:--mm DC:28mm  
LT:166mm ANS:49mm LC:20mm

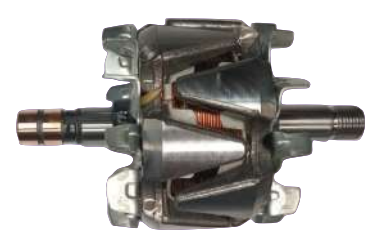

**3330085/33085**

Bosch 12V - 90A  
Toyota Hilux desde 2016  **BOSCH**

DN:89mm CMP:12 ANV:75mm DC:13mm  
LT:142mm ANS:48mm LC:20mm

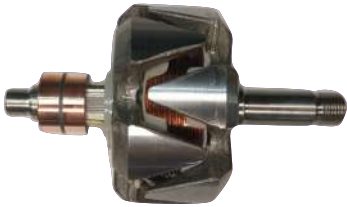

**3330004/33004**

Bosch 12V - 70A  
RENAULT, GOL  **BOSCH**

DN:99mm CMP:12 ANV:--mm DC:28mm  
LT:153mm ANS:49mm LC:20mm

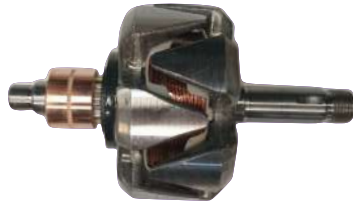

**3330017/33017**

Bosch 12V - 70A  
MB 1114 1518 1620  **BOSCH**

DN:89mm CMP:12 ANV:--mm DC:28mm  
LT:157mm ANS:49mm LC:20mm

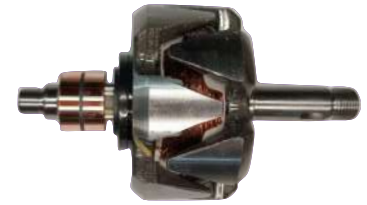

**3330019/33019**

Bosch 24V - 60A  
MB 1114 1518 1620  **BOSCH**

DN:89mm CMP:12 ANV:--mm DC:28mm  
LT:157mm ANS:49mm LC:20mm

**3330071**

Bosch 12V - 80A  
Ranger, Sprinter maxion c/depresor  **BOSCH**

DN:89mm CMP:12 ANV:--mm DC:28mm  
LT:157mm ANS:49mm LC:20mm

**3330050**

Bosch 12V - 85A  
Toyota hasta 2015  **BOSCH**

DN:89mm CMP:12 ANV:--mm DC:28mm  
LT:157mm ANS:49mm LC:20mm

F000BL0769



**3330140**

Bosch 24V - 80A  
Axor Atego  **BOSCH**

DN:103mm CMP:12 ANV:78m DC:16mm  
LT:155mm ANS:48mm LC:20mm

# LINEA J (VIOLETA)

**VMV**  
IMPORTACIONES

**ROTORES 30**

DN: Diámetro núcleo - LT: Largo total - CMP: Cant. masas polares - ANS: Ancho núcleo solo - ANV: Ancho con ventilador - LC: Largo colector - DC: Diámetro colector



**3330047/33047**

Bosch 12V - 90A  
MB 1518,1620



DN:100mm CMP:12 ANV:--mm DC:28mm  
LT:174mm ANS:51mm LC:20mm



**3330066/33066**

Bosch 12V - 100A

VW Gol Senda



DN:101mm CMP:12 ANV:--mm DC:28mm  
LT:158mm ANS:52mm LC:19mm



**3330090/33090**

Bosch 24V - 80A

VOLVO CAMION



DN:101mm CMP:12 ANV:--mm DC:28mm  
LT:167mm ANS:52mm LC:20mm



**3330091/33091**

Bosch 24V - 80A

VOLVO SCANIA 112



DN:101mm CMP:12 ANV:--mm DC:28mm  
LT:175mm ANS:53mm LC:20mm



**3330014/33014**

Bosch 12V - 90A

FORD CUMINS



DN:94mm CMP:12 ANV:--mm DC:28mm  
LT:152mm ANS:48mm LC:20mm

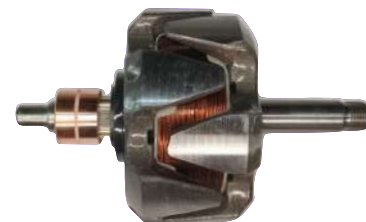

**3330096/33096**

Bosch 24V - 80A

ESCANIA MB VOLVO



DN:103mm CMP:12 ANV:--mm DC:28mm  
LT:175mm ANS:56mm LC:20mm



**3330027/33027**

Bosch 24V - 80A

Scania 112



DN:114mm CMP:12 ANV:--mm DC:27mm  
LT:179mm ANS:57mm LC:20mm



**3330033/33033**

Bosch 12V - 90A

GOL, POLO, BORA, FOX



DN:94mm CMP:12 ANV:79mm DC:16mm  
LT:155mm ANS:51mm LC:20mm



**3330001**

Bosch 24V - 80A

MB Electrónico todos



DN:103,5mm CMP:12 ANV:85mm DC:16mm  
LT:156mm ANS:58mm LC:19mm

# LINEA J (VIOLETA)

**VMV**  
IMPORTACIONES

**ROTORES 31**

DN: Diámetro núcleo - LT: Largo total - CMP: Cant. masas polares - ANS: Ancho núcleo solo - ANV: Ancho con ventilador - LC: Largo colector - DC: Diámetro colector



**3330040/33040**

Bosch 24V - 110A  
MB Electrónico todos  **BOSCH**  
DN:104mm CMP:12 ANV:85mm DC:16mm  
LT:167mm ANS:57mm LC:20mm



**3330032/33032**

Bosch 24V - 110A  
MB Electrónico todos  **BOSCH**  
DN:103mm CMP:12 ANV:84mm DC:16mm  
LT:163mm ANS:55mm LC:20mm



**3330063/33063**

Bosch 24V - 110A  
MB Electrónico todos  **BOSCH**  
DN:111mm CMP:12 ANV:84mm DC:16mm  
LT:167mm ANS:57mm LC:20mm



**3330000/33000**

Bosch 24V - 110A  
MB Electrónico todos  **BOSCH**  
DN:112mm CMP:12 ANV:79mm DC:16mm  
LT:165mm ANS:57mm LC:18mm



**3330065/33065**

Bosch 24V - 100A  
Euro Cargo Iveco  **BOSCH**  
DN:112mm CMP:-12 ANV:85mm DC:16mm  
LT:167mm ANS:57mm LC:18mm



**3330097/33097**

Bosch 24V - 110A  
UNIVERSAL  **BOSCH**  
DN:108mm CMP:12 ANV:87mm DC:15mm  
LT:207mm ANS:59mm LC:20mm



**3330080/33080**

BOSCH 12V - 100A  
MB 1620  **BOSCH**  
DN:112mm CMP:12 ANV:82mm DC:16mm  
LT:167mm ANS:56mm LC:18mm



**3330055/33055**

BOSCH 24V - 150A  
MB 1620  **BOSCH**  
DN:112mm CMP:12 ANV:82mm DC:16mm  
LT:167mm ANS:56mm LC:18mm



**3330081/33081**

BOSCH 24V - 150A  
MB 1620  **BOSCH**  
DN:112mm CMP:12 ANV:82mm DC:16mm  
LT:167mm ANS:56mm LC:18mm

DN: Diámetro núcleo - LT: Largo total - CMP: Cant. masas polares - ANS: Ancho núcleo solo - ANV: Ancho con ventilador - LC: Largo colector - DC: Diámetro colector



**3330031/33031**

Valeo 12V - 100A  
P306, P405, Nafta, Diesel **Valeo**

DN:98mm CMP:12 ANV:72mm DC:14mm  
LT:148mm ANS:49mm LC:22mm

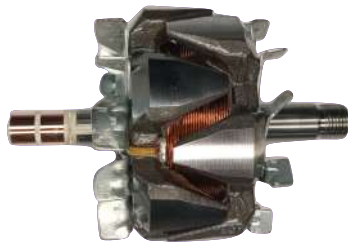

**3330057/33057**

Valeo- P306, PARTNER 12V - 100A  
**Valeo**

DN:99mm CMP:12 ANV:71.5mm DC:15mm  
LT:144mm ANS:50mm LC:20mm

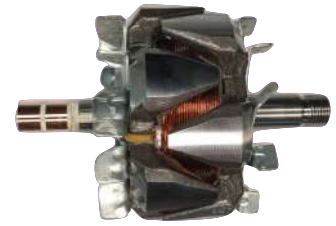

**3330058/33058**

Valeo- P206-306 12V - 90A  
**Valeo**

DN:99mm CMP:12 ANV:71.5mm DC:15mm  
LT:144mm ANS:50mm LC:20mm

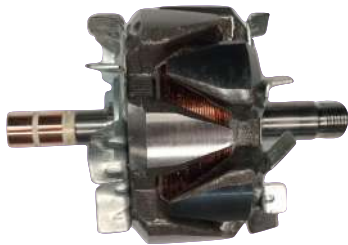

**3330095/33095**

Valeo- FIESTA ECO SPORT 12V - 90A  
**Valeo**

DN:99mm CMP:12 ANV:71mm DC:15mm  
LT:144mm ANS:49mm LC:20mm



**3330007/33007**

LUCAS UNIVERSAL 12V - 70A  
**Lucas**

DN:89mm CMP:12mm ANV: DC:21mm  
LT:145mm ANS:46MM LC:20mm

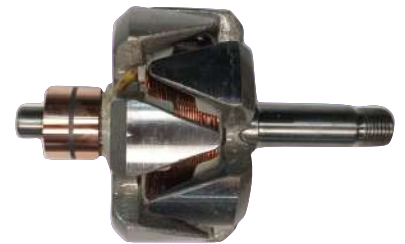

**3330070/33070**

LUCAS UNIVERSAL 24V - 70A  
**Lucas**

DN:89MM CMP:12 ANV:mm DC:28Mm  
LT:145MM ANS46MM LC:20MM

- AN: Ancho Núcleo - AB: Ancho Bobinado - DIN: Diámetro Interior - DEX: Diámetro Exterior -



**3430022/4025**

Nipondenso - Hilux hasta 2005  
Con depresor

AN: 27,5mm DIN: 92mm  
AB: 63mm DEX: 118mm



**3430023/4026**

Nipondenso - Hilux desde 2005 hasta 2015

AN: 27,5mm DIN: 87mm  
AB: 54mm DEX: 111mm



12V - 90A

**3430064/34064**

Marelli - Palio, Siena

AN: 30mm DIN: 92mm  
AB: 63mm DEX: 118mm



12V - 120A

**3430094/34094**

MARELLI  
Focus-Fiesta

AN: 32mm DIN: 99mm  
AB: 58mm DEX: 130mm



12V - 80A

**3430013/34013**

Marelli - Palio, Siena

AN: 33mm DIN: 100mm  
AB: 68mm DEX: 130mm



24V - 90A

**3430018/34018**

Delco - Universal Case Don Roque

AN: 29mm DIN: 107mm  
AB: 60mm DEX: 143mm



12V - 150A

**3430005/34005**

Delco - Universal Case Don Roque

AN: 29mm DIN: 107mm  
AB: 60mm DEX: 143mm



12V - 80A

**3430114**

Cobal-Onix-Prisma





12V - 80A

**3430061/34061**

Bosch- Ford Camión Cargo

AN: 24,5mm DIN: 89mm  
AB: 51mm DEX: 125mm



24V - 60A

**3430060/34060**

Bosch - Ford Camión Cargo

AN: 24,5mm DIN: 89mm  
AB: 51mm DEX: 125mm



12V - 80A

**3430071**

Bosch- Ranger-Sprinter Maxion

AN: mm DIN: mm  
AB: mm DEX: mm



12V - 70A

**3430004/34004**

Bosch - RENAULT, GOL

AN: 24mm DIN: 89mm  
AB: 51mm DEX: 125mm



12V - 70A

**3430017/34017**

Bosch - MB 1114 1518 1620

AN: 24mm DIN: 89mm  
AB: 51mm DEX: 125mm



24V - 60A

**3430019/34019**

Bosch - MB 1114 1518 1620

AN: 24mm DIN: 89mm  
AB: 51mm DEX: 125mm



12V - 90A

**3430047/34047**

Bosch - MB 1518,1620

AN: 24mm DIN: 100mm  
AB: 55mm DEX: 138mm



12V - 90A

**3430066/34066**

Bosch - VW Gol Senda

AN: 24mm DIN: 101mm  
AB: 60mm DEX: 138mm



24V-80A

**3430090**

Bosch - VOLVO CAMION

AN: 25mm DIN: 100mm  
AB: 55mm DEX: 138mm





24V-80A

**3430091**

Bosch - SCANIA 112

AN: 25mm DIN: 100mm  
AB: 55mm DEX: 138mm



**BOSCH**



12V-90A

**3430085**

Bosch - Hilux desde el 2015

AN: mm DIN: mm  
AB: mm DEX: mm



**BOSCH**

F000BL0769



24V-80A

**3430140**

Bosch - Axor Atego

AN: 27mm DIN: 103mm  
AB: 70mm DEX: 136mm



**BOSCH**



12V-90A

**3430014**

Bosch - FORD CUMINS

AN: 26mm DIN: 94mm  
AB: 55mm DEX: 125mm



**BOSCH**



24V-80A

**3430096**

Bosch - ESCANIA MB VOLVO

AN: 28mm DIN: 104mm  
AB: 59mm DEX: 142mm



**BOSCH**



24V - 55A

**3430027/34027**

Bosch - Scania 112

AN: 30mm DIN: 103mm  
AB: 60mm DEX: 141mm



**BOSCH**



12V-90A

**3430050**

Bosch - HILUX

AN: 32mm DIN: 93mm  
AB: 65mm DEX: 125mm



**BOSCH**



12V-90A

**3430033**

Bosch - GOL POLO BORA FOX

AN: 32mm DIN: 94mm  
AB: 69mm DEX: 125mm



**BOSCH**



24V-80A

**3430001**

Bosch - MB Electrónico todos

AN: 33mm DIN: 104mm  
AB: 71mm DEX: 136mm



**BOSCH**





24V - 80A

**3430040/34040**

Bosch SCANIA MB VOLVO

AN: 33mm DIN: 104mm  
AB: 76mm DEX:136mm



12V - 120A

**3430032/34032**

Bosch GOL, AMAROK, BORA

AN: 33mm DIN: 104mm  
AB: 75mm DEX:136mm



12V - 150A

**3430063/34063**

Bosch MB SPRINTER 1624

AN: 36mm DIN: 111mm  
AB: 73mm DEX:142mm



24V - 100A

**3430000/34000**

Bosch - MB Electrónico todos

AN: 36mm DIN: 111mm  
AB: 72mm DEX: 141mm



24V - 90A

**3430065/34065**

Bosch - Euro Cargo Iveco

AN: 36mm DIN: 112mm  
AB: 72mm DEX: 142mm



12V - 200A

**3430097/34097**

Bosch UNIVERSAL

AN: 37mm DIN: 108mm  
AB: 76mm DEX:144mm



12V - 150A

**3430080/34080**

Bosch MB 1620

AN: 39mm DIN:111 mm  
AB: 77mm DEX:145 mm/153mm



24V-150A

**3430055**

Bosch - MB Electrónico todos

Bosch MB 1620  
AN: 39mm DIN: 111mm  
AB: 77mm DEX:145 mm/153mm



24V - 150A

**3430081/34081**

Bosch MB 1620

AN: 39mm DIN: 111mm  
AB: 77mm DEX:145 mm/153mm



- AN: Ancho Núcleo - AB: Ancho Bobinado - DIN: Diámetro Interior - DEX: Diámetro Exterior -



12V - 90A

**3430031/34031**

Valeo - P306, P405, Nafta, Diesel

AN: 25mm DIN: 97mm  
AB: 60mm DEX: 128mm



12V-100A

**3430057**

Valeo - P306, PARTNER

AN: 25mm DIN: 99mm  
AB: 60mm DEX: 128mm



12V-90A

**3430058**

Valeo P206-306

AN: 25mm DIN: 99mm  
AB: 60mm DEX: 128mm



12V-90A

**3430095**

Valeo - FIESTA ECO SPORT

AN: 25 mm DIN: 99mm  
AB: 61mm DEX: 127mm



12V-70A

**3430007**

LUCAS-UNIVERSAL

AN: 23mm DIN: 89mm  
AB: 47mm DEX: 125mm



24V-70A

**3430070**

LUCAS-UNIVERSAL

AN: 23mm DIN: 89mm  
AB: 47mm DEX: 12.5mm



C: Canales - DE: Diámetro Exterior - A: Ancho - DI: Diámetro Interior - G: Giro - T: Medida de Tornillo - FT: Fuerza de Tensión

**15389**

C	6
DE	61
A	41
DI	17
G	D
T	M16
FT	8.6 Kg

 Polea con embrague Valeo  
 Clio - Megane - Kangoo

**15374**

C	6
DE	75
A	41.5
DI	17
G	D
T	M16
FT	8.6 Kg

 Polea con embrague Valeo  
 S100 Frontier - MWM 2.8

**15469**



C	6
DE	75
A	41.5
DI	17
G	D
T	M16
FT	8.6 Kg

 Polea con embrague Valeo  
 Logan - Clio -Kangoo - Megane  
 Scenic - Simbol

**15468**

C	5
DE	75
A	38.5
DI	17
G	D
T	M16
FT	8.6 Kg

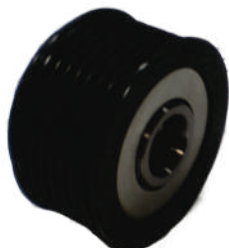
 Polea con embrague Mitsubishi  
 Motores Renault 1.5 Diesel

**15403**

C	7
DE	61.5
A	35.5
DI	17
G	D
T	M16
FT	8.6 Kg

 Ford Transit - Toyota Hilux 2.5  
 Bosch

**15409**

C	6
DE	61
A	35.5
DI	17
G	D
T	M16
FT	8.6 Kg

 VW Gol - Saveiro - Cady 1.9 D  
 Bosch

**15381**

C	6
DE	55
A	39.3
DI	17
G	D
T	M16
FT	8.6 Kg

 Ford Escort 1.8 D - Gol  
 Cady 1.9 - Polo  
 Bosch

**15509**

C	7
DE	65
A	42
DI	15
G	D
T	M14
FT	8.6 Kg

 Toyota Hilux 2.5 TD  
 Nippondenso

**15378**

C	6
DE	61
A	41.1
DI	17
G	D
T	M16
FT	8.6 Kg

 Bora - Golf 1.9 TDI  
 Bosch

**15437**

C	6
DE	59
A	34.3
DI	17
G	D
T	M16
FT	8.6 Kg

 Fiesta Diesel 2004>  
 Peugeot 206 D  
 Valeo

C: Canales - DE: Diámetro Exterior - A :Ancho - DI: Diámetro Interior - G: Giro - T: Medida de Tornillo - FT: Fuerza de Tensión

### 15509A



C	7
DE	65
A	42
DI	17
G	D
T	M14
FT	8.6 Kg

Toyota Hilux 3.0 TD  
Nippondenso

### 15384



C	5
DE	61
A	37
DI	17
G	D
T	M16
FT	8.6 Kg

Polo - Gol - Passat 1.9 TD  
Bosch

### 15453



C	6
DE	59
A	39
DI	17
G	D
T	M16
FT	8.6 Kg

P306 - 206 - 207 TD  
Valeo

### 15431



C	7
DE	64
A	41.5
DI	17
G	D
T	M16
FT	8.6 Kg

Nissan - Frontier - Patrol  
Terrano TD  
Hitachi

### 15380



C	5
DE	61
A	35.5
DI	17
G	D
T	M16
FT	8.6 Kg

Ford Escort - Fiesta 1.8 D  
Bosch - Valeo

### 15410



C	6
DE	53.4
A	37
DI	17
G	D
T	M16
FT	8.6 Kg

Renault Laguna - Master  
motor F9Q TD  
Valeo

### 15396



C	6
DE	54.6
A	40
DI	17
G	D
T	M16
FT	8.6 Kg

P206 - 307 - Fiat Ducato  
Citroën Berlingo  
Valeo

### 15462



C	6
DE	63
A	37
DI	17
G	D
T	M17
FT	8.6 Kg

Ford Focus 1.8 D  
Marelli

### 15393



C	6
DE	55
A	39.3
DI	17
G	D
T	M16
FT	8.6 Kg

MB Sprinter motor CDI  
Bosch

### 15423



C	6
DE	54.6
A	36
DI	17
G	D
T	M16
FT	8.6 Kg

Corso - Astra - Vectra - Safira - Meriva  
Bosch

# LINEA J (VIOLETA)

C: Canales - DE: Diámetro Exterior - A: Ancho - DI: Diámetro Interior - G: Giro - T: Medida de Tornillo - FT: Fuerza de Tensión

**15318**



C	6
DE	56
A	65.5
DI	17
G	D
T	M16
FT	8.6 Kg

Ford Transit - Renault Master  
Bosch

**15319**



C	6
DE	75
A	46.5
DI	17
G	D
T	M17
FT	8.6 Kg

Fiat Ducato  
Marelli

**15320**



C	7
DE	61.5
A	44.3
DI	17
G	D
T	M16
FT	8.6 Kg

Ford Transit - Diesel  
Marelli

**15513**



C	7
DE	64,5
A	38
DI	17
G	D
T	M14
FT	8.6 Kg

Toyota Hilux  
Nippondenso

**15435**



C	5
DE	59
A	39.5
DI	17
G	D
T	M16
FT	8.6 Kg

Fiat Doblo - Palio - Stylo  
Chevrolet Meriva - Corsa

**15452**



C	7
DE	62.7
A	38.5
DI	17
G	D
T	M16
FT	8.6 Kg

Toyota Hilux 2.5, 3.0  
Desde 2006 hasta 2015  
Bosch

**15395**



C	6
DE	55
A	39.3
DI	17
G	D
T	M16
FT	8.6 Kg

MB Sprinter - Maxion - Utilitarios  
Bosch

**15514**



C	6
DE	55
A	39.3
DI	17
G	D
T	M16
FT	8.6 Kg

VW Golf - Vento - Passat - Fox  
Bosch

**15422**



C	6
DE	54.6
A	36
DI	17
G	D
T	M16
FT	8.6 Kg

Chevrolet Astra - Safira - Vectra - Meriva  
Bosch

**15377**



C	6
DE	61
A	55,6
DI	17
G	D
T	M16
FT	8.6 Kg

MB 220 - Sprinter - Todos  
Bosch

C: Canales - DE: Diámetro Exterior - A: Ancho - DI: Diámetro Interior - G: Giro - T: Medida de Tornillo - FT: Fuerza de Tensión

### 15449



C	6
DE	59
A	39
DI	17
G	D
T	M16
FT	8.6 Kg

Fiat Doblo - Idea - Línea - Punto  
Strada - GM Agile - Corsa - Meriva  
Bosch

### 15428



C	6
DE	63
A	40
DI	17
G	D
T	M14
FT	8.6 Kg

Dodge Journey - Caravan - Ram  
Chrysler  
Denso

### 15469A



C	6
DE	76.5
A	42.5
DI	
G	D
T	M16
FT	8.6 Kg

Polea con embrague Valeo  
Logan - Clio - Kangoo - Megane  
Scenic - Simbol  
Con goma

### 15468A



C	5
DE	76.5
A	40.5
DI	
G	D
T	M16
FT	8.6 Kg

Polea con embrague Mitsubishi  
Motores Renault 1.5 Diesel  
Con goma

### 15522



C	7
DE	69
A	40.5
DI	17
G	D
T	M17
FT	8.6 Kg

Nissan Frontier - Tida  
Mitsubishi

### 15462A



C	6
DE	63
A	167
DI	17
G	D
T	M17
FT	8.6 Kg

Ford Focus 1.8 D  
Marelli  
Con soporte, manchón y eje

### 15562



C	7
DE	53
A	40.3
DI	17
G	D
T	M16
FT	8.6 Kg

Scenic Laguna - Megane  
Valeo

### 15432



C	5
DE	53.4
A	38
DI	17
G	D
T	M16
FT	8.6 Kg

Master - Megane - Laguna - F9Q  
Valeo

### 15505



C	5
DE	61
A	37,5
DI	17
G	D
T	M16
FT	8.6 Kg

Audi TT 2.5 FSI Coupe Quattro, Roadster  
Quattro  
VW New Beetle, Cabrio 2,5 l, Golf VI 2,5 l,  
Jetta 2,5l  
Bosch

### 15523



C	5
DE	53,5
A	33,3
DI	17
G	D
T	M16
FT	8.6 Kg

Renault Laguna II 1.9 DCI, Grandtour 1.9 DCI  
VW Eos 2.0 FSI, TFSI, Golf Plus 1.6  
Bosch

C: Canales - DE: Diámetro Exterior - A: Ancho - DI: Diámetro Interior - G: Giro - T: Medida de Tornillo - FT: Fuerza de Tensión

**15375**



C	6
DE	55,6
A	36,4
DI	17,6
G	D
T	M16
FT	8,6KG

MERCEDES BENZ VITO  
BOSCH

**15382**



C	5
DE	56,2
A	36,6
DI	17
G	D
T	M16
FT	8,6KG

VW GOL , PASSAT 1.9  
BOSCH

**15392**



C	6
DE	56,2
A	36,4
DI	17
G	D
T	M16
FT	8,6KG

PASSAT BOSCH

**15450**



C	6
DE	54,3
A	38,3
DI	17,6
G	D
T	M16
FT	8,6KG

PEUGEOT 306,307,406  
CITROEN C3,C4,C5 DIESEL  
BOSCH

**15455**

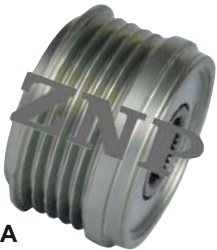

C	5
DE	54
A	36,4
DI	17
G	D
T	M16
FT	8,6KG

S-10 ,ASTRA ,CORSA  
VECTRA ,BOSCH

**15457**



C	6
DE	54,2
A	41,8
DI	17
G	D
T	M16
FT	8,6KG

FIESTA, FACCIÓN, VICTIO

**15458**



C	6
DE	49,1
A	31,8
DI	17,6
G	D
T	M16
FT	8,6KG

VMW AUTOS BOSCH

**15466**



C	5
DE	60
A	36,4
DI	17
G	D
T	M16
FT	8,6KG

HYUNDAI KIA VALEO

**15467**



C	6
DE	55
A	43,6
DI	17
G	D
T	M16
FT	8,6KG

DUSTER ,LOGAN.CLIO, KANGOO  
BOSCH

**15492**



C	7
DE	49
A	38,2
DI	17
G	D
T	M16
FT	8,6KG

RENAULT , CAPTUR  
MASTER , LAGUNA, BOSCH

C: Canales - DE: Diámetro Exterior - A: Ancho - DI: Diámetro Interior - G: Giro - T: Medida de Tornillo - FT: Fuerza de Tensión

**15502**



C	7
DE	55
A	41,1
DI	17
G	D
T	M14
FT	8,6KG

TOYOTA CAMRY,RAV4

**15503**



C	7
DE	52,5
A	41,5
DI	17
G	D
T	M14
FT	8,6

TOYOTA RAV4

**15512**



C	6
DE	55
A	46,7
DI	17
G	D
T	M16
FT	8,6KG

LOGAN,CLIO,KANGOO  
MITSUBISHI

**15607**

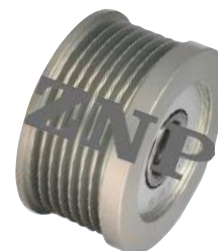

C	7
DE	64,7
A	40,8
DI	17
G	D
T	M17
FT	8,6KG

NISSAN FRONTIER,MITSUBISHI

**15565**



C	6
DE	49,6
A	42
DI	17
G	D
T	M16
FT	8,6KG

CITROCEN C3  
PEUGEOT 207 VALEO

**15567**



C	7
DE	57,5
A	42,4
DI	15
G	D
T	M14
FT	8,6

HILUX Sw4 TOYOTA

**15575**



C	6
DE	55
A	43.1
DI	17
G	D
T	M16
FT	8,6KG

LOGAN,DUSTER,  
CLIO ,MEGAN,BOSCH

**15581**



C	7
DE	50
A	49,3
DI	17
G	D
T	M16
FT	8.6KG

MERCES BENZ VITO  
SPRINTER VALEO

**15584**



C	7
DE	49
A	38.7
DI	17
G	D
T	M17
FT	8.6KG

RENAULT , CENIC  
COLEOS,LAGUNA,MITSUBISHI

**15622**



C	6
DE	53.7
A	40.7
DI	17
G	D
T	M16
FT	8.6KG

CHEVROLET CRUZE, ASTRA



C: Canales - DE: Diámetro Exterior - A: Ancho - DI: Diámetro Interior - G: Giro - T: Medida de Tornillo - FT: Fuerza de Tensión

**15629**



C	6
DE	54
A	42.2
DI	17
G	D
T	M16
FT	8.6KG

CITROEN C3, FORD FIESTA  
FIAT DUCATO

**15624**



C	6
DE	50
A	47.7
DI	17
G	D
T	M16
FT	8.6KG

MB SPRINTER, VITO

**15675**

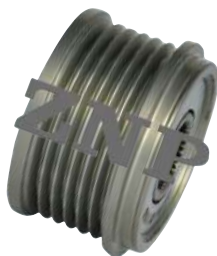

C	6
DE	54
A	33.5
DI	17
G	D
T	M16
FT	8.6KG

CITROEN C3, BERLINGO  
PEUGEOT 207, BOSCH

**15697**



C	6
DE	55.9
A	39.5
DI	17.6
G	D
T	M16
FT	8.6KG

VW AMAROK BOSCH

**15708**



C	6
DE	54
A	43.6
DI	17
G	D
T	M14
FT	8.6KG

FIAT TORO, JEEP RENEGADE  
COMPACTS, NIPONDENSO

**15713**



C	7
DE	60
A	40
DI	17
G	D
T	M16
FT	8.6KG

HYUNDAI, KIA VALEO

**16006**



C	6
DE	55
A	46.4
DI	17
G	D
T	M14
FT	8.6KG

TOYOTA COROLLA DENSO

C	x
DE	x
A	x
DI	x
G	x
T	x
FT	x

C	x
DE	x
A	x
DI	x
G	x
T	x
FT	x

C	x
DE	x
A	x
DI	x
G	x
T	x
FT	x